

These are miscellaneous cam-controlled reader circuits.

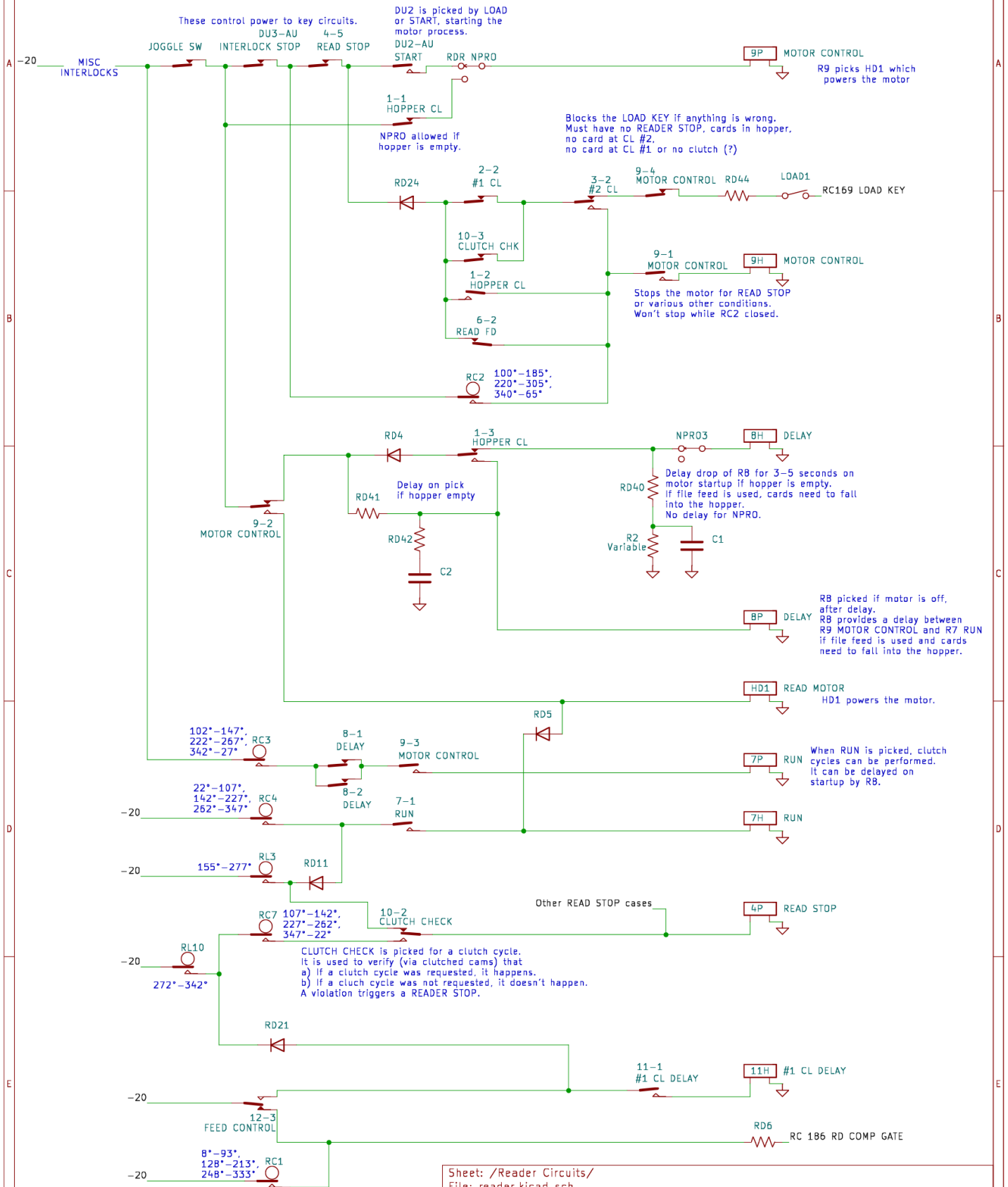

Sheet: /Reader Circuits/ File: reader.kicad_sch		
<b>Title: IBM 1402 Reader Circuits</b>		
Size: USLetter	Date: 2024-02-28	Rev: 0.2
Ken Shirriff		Id: 1/4