



IBM Customer Engineering

Service Index

IBM 1402 Reader Punch

Minor Revision

This edition, 229-4016-1 is a minor revision of the preceding edition, but it does not obsolete 229-4016. Numerous changes of a minor nature have been made throughout the manual.

TABLE OF CONTENTS

1	LOCATIONS		
	Physical Locations -----		2
	Read Connector (RC)-----		4
	Punch Connector (PC)-----		6
	Power Connector (PW)-----		8
	Fuse Chart -----		9
	Minus 60 Volt Supply -----		10
	Feed Schematics -----		12
2	READER		
	Reader Stops -----		2
	Reader Clutch -----		4
	Reader Checks-----		6
	Solar Cell CB-----		12
	Solar Cell CB Scope Pictures-----		14
	Brushes-----		16
	Brush Scope Pictures-----		18
	Noise -----		20
3	TRANSPORT		
	Transport -----		2
	51-80 -----		4
4	PUNCH		
	Punch Stops -----		1
	Off Punching and Jams-----		2
	Punch Transport Adjustments -----		4
	Punch Transport Timing -----		5
	Punch Checks-----		6
	PA CBs -----		10
	Punch Failures -----		12
	Punch Unit -----		14
	Cam Follower Unit -----		15
5	LOGIC AND DATA FLOW		
	Input Output Data Flow-----		2
	Lights -----		3
	Read Start and Run -----		4
	Reader Sequence Charts -----		5
	Read Logic Flow -----		9
	Hole Count -----		14
	Read Col Binary -----		16
	Punch Start and Run -----		17
	Punch Stacker Select Sequence Chart -----		18
	Punch Logic Flow -----		19
	Punch Col Binary -----		24
	Punch Feed Read -----		25

NOTE- ALL POWER SUPPLIES ARE LOCATED
IN THE PROCESSING UNIT ON THE 1402 MODEL 3.

1-2 locations

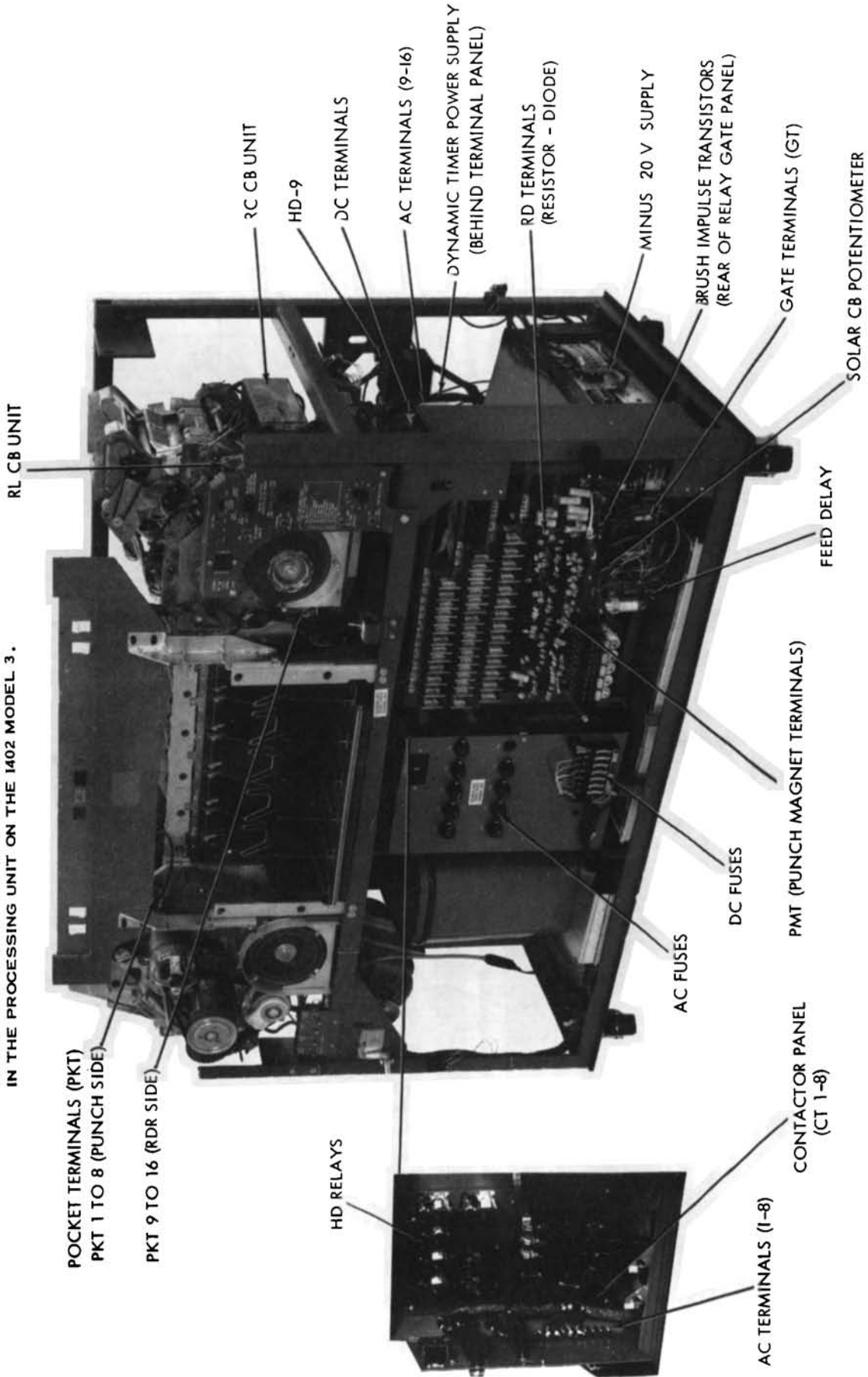

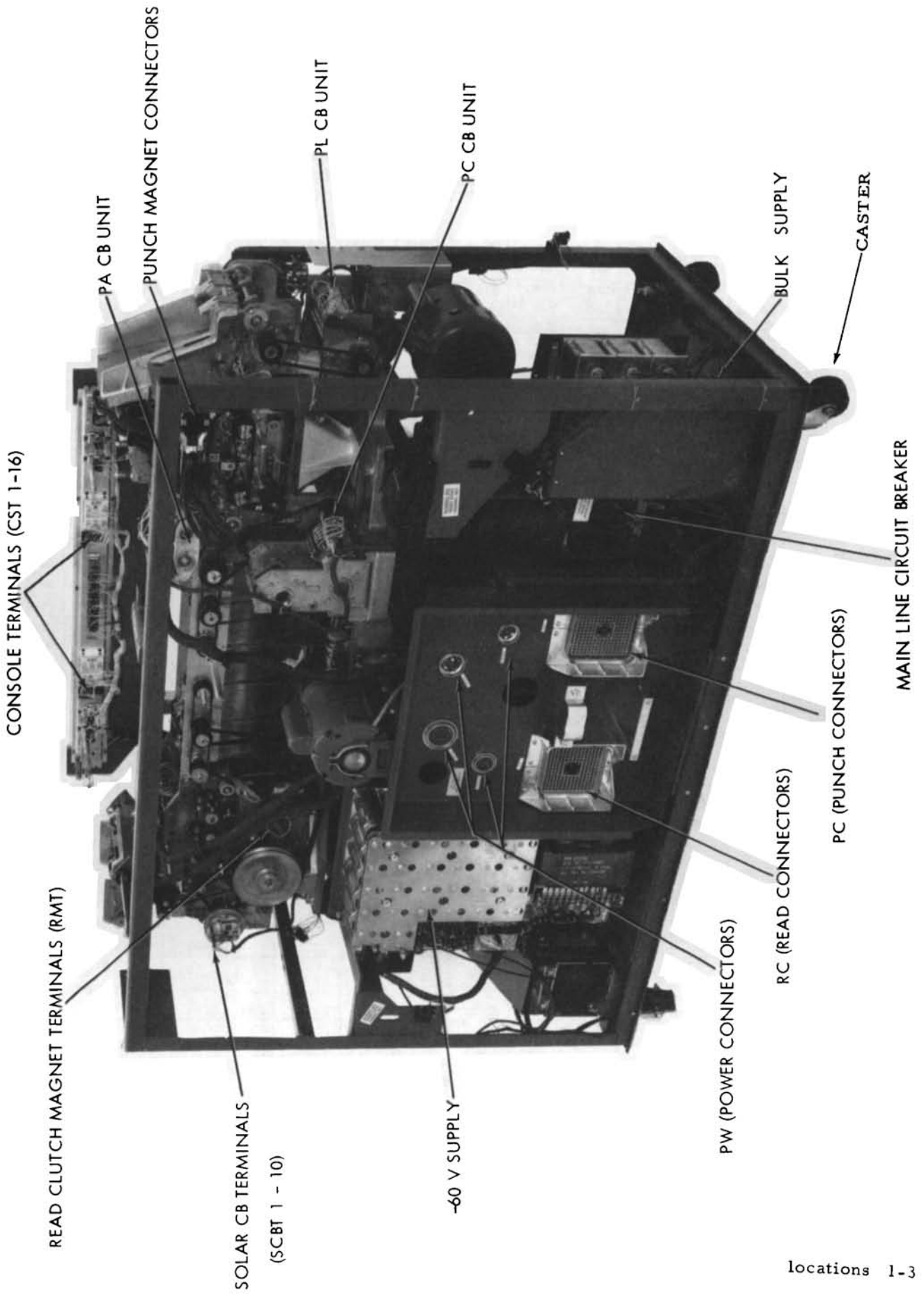

R C CONNECTOR

15	14	13	12	11	10	9	8	7	6	5	4	3	2	1					
01A1	01A1	01A1	01A1	01A1	01A1	01A1	01A1	01A1	01A1	01A1	01A1	01A1	01A1	01A1					
G01Q	G01P	G01N	G01M	G01L	G01K	G01J	G01H	G01G	G01F	G01E	G01D	G01C	G01B	G01A					
30	29	28	27	26	25	24	23	22	21	20	19	18	17	16					
01A1	01A1	01A1	01A1	01A1	01A1	01A1	01A1	01A1	01A1	01A1	01A1	01A1	01A1	01A1					
G02P	G02N	G02M	G02L	G02K	G02J	G02H	G02G	G02F	G02E	G02D	G02C	G02B	G02A	G01R					
45	44	43	42	41	40	39	38	37	36	35	34	33	32	31					
01A1	01A1	01A1	01A1	01A1	01A1	01A1	01A1	01A1	01A1	01A1	01A1	01A1	01A1	01A1					
G03N	G03M	G03L	G03K	G03J	G03H	G03G	G03F	G03E	G03D	G03C	G03B	G03A	G02R	G02Q					
60	59	58	57	56	55	54	53	52	51	50	49	48	47	46					
01A1	01A1	01A1	01A1	01A1	01A1	01A1	01A1	01A1	01A1	01A1	01A1	01A1	01A1	01A1					
G04M	G04L	G04K	G04J	G04H	G04G	G04F	G04E	G04D	G04C	G04B	G04A	G03R	G03Q	G03P					
75	74	73	72	71	70	69	68	67	66	65	64	63	62	61					
01A1	01A1	01A1	01A1	01A1	01A1	01A1	01A1	01A1	01A1	01A1	01A1	01A1	01A1	01A1					
G05L	G05K	G05J	G05H	G05G	G05F	G05E	G05D	G05C	G05B	G05A	G04R	G04Q	G04P	G04N					
85	84	83	82	81	1401 TERMINATION OF R C CABLE					80	79	78	77	76					
01A1	01A1	01A1	01A1	01A1						01A1	01A1	01A1	01A1	01A1	01A1	01A1	01A1	01A1	
G06E	G06D	G06C	G06B	G06A						G05R	G05Q	G05P	G05N	G05M	G05L	G05K	G05J	G05I	
95	94	93	92	91						G06K	G06J	G06H	G06G	G06F	G06E	G06D	G06C	G06B	G06A
01A1	01A1	01A1	01A1	01A1						G07D	G07C	G07B	G07A	G06R	G06Q	G06P	G06O	G06N	G06M
G06Q	G06P	G06N	G06M	G06L						G07D	G07C	G07B	G07A	G06R	G06Q	G06P	G06O	G06N	G06M
105	104	103	102	101	1401 TERMINATION OF R C CABLE					100	99	98	97	96					
01A1	01A1	01A1	01A1	01A1						G07D	G07C	G07B	G07A	G06R	G06Q	G06P	G06O	G06N	G06M
G07J	G07H	G07G	G07F	G07E						G07D	G07C	G07B	G07A	G06R	G06Q	G06P	G06O	G06N	G06M
115	114	113	112	111						G07P	G07N	G07M	G07L	G07K	G07J	G07I	G07H	G07G	G07F
01A1	01A1	01A1	01A1	01A1						G07P	G07N	G07M	G07L	G07K	G07J	G07I	G07H	G07G	G07F
G08C	G08B	G08A	G07R	G07Q						G07P	G07N	G07M	G07L	G07K	G07J	G07I	G07H	G07G	G07F
125	124	123	122	121	1401 TERMINATION OF R C CABLE					120	119	118	117	116					
01A1	01A1	01A1	01A1	01A1						G08H	G08G	G08F	G08E	G08D	G08C	G08B	G08A	G07R	G07Q
G08N	G08M	G08L	G08K	G08J						G08H	G08G	G08F	G08E	G08D	G08C	G08B	G08A	G07R	G07Q
140	139	138	137	136						135	134	133	132	131	130	129	128	127	126
01A1	01A1	01A1	01A1	01A1						01A1	01A1	01A1	01A1	01A1	01A1	01A1	01A1	01A1	01A1
G09M	G09L	G09K	G09J	G09H						G09G	G09F	G09E	G09D	G09C	G09B	G09A	G08R	G08Q	G08P
155	154	153	152	151	150	149	148	147	146	145	144	143	142	141					
01A1	01A1	01A1	01A1	01A1	01A1	01A1	01A1	01A1	01A1	01A1	01A1	01A1	01A1	01A1					
G10L	G10K	G10J	G10H	G10G	G10F	G10E	G10D	G10C	G10B	G10A	G09R	G09Q	G09P	G09N					
170	169	168	167	166	165	164	163	162	161	160	159	158	157	156					
01B4	01B4	01B4	01B4	01B4	01B4	01B4	01B4	01B4	01B4	01A1	01A1	01A1	01A1	01A1					
G02A	G01N	G01B	G02R	G02Q	G02P	G02N	G01F	G02L	G02K	G10R	G10Q	G10P	G10N	G10M					
185	184	183	182	181	180	179	178	177	176	175	174	173	172	171					
01B4	01B4	01B4	01B4	01B4	01B4	01B4	01B4	01B4	01B4	01B4	01B4	01B4	01B4	01B4					
G02H	G02G	G02F	G02E	G01A	G02D	G02C	G01E	G01D	G01R	G02B	G02J	G01C	G01M	G01L					
200	199	198	197	196	195	194	193	192	191	190	189	188	187	186					
SPARE	01B4	SPARE	SPARE	SPARE	SPARE	01B4	SPARE	01B4	01B4	SPARE	SPARE	01B4	01B4	01B4					
	G02M					G01P		G01G	G01Q			G01J	G01K	G01H					

READER CONNECTOR WIRES (RC)

CONNECTOR POS (RC)	WIRE DIAGRAM LOC	LOGIC REF	DESCRIPTION
1 TO 80	7B-8B	42.40.51.1	COL 1 TO 80-NO 1 READ BRUSH
81 TO 160	7B-8B	42.40.51.1	COL 1 TO 80-NO 2 READ BRUSH
161	6B	36.19.11.2	START KEY (+U START KEY RD NC)
162			
163	8A	36.10.21.2	SOLAR CB 1 ST RD (SC CB-1)
164			
165			
166			
167			
168	4A	36.18.11.2	READ STOP (-T READ STOP)
169	4B	36.10.21.2	LOAD KEY (-T LOAD KEY)
170	6A	36.10.11.2	READ CLUTCH (-T RD CLUTCH)
171	6A	36.10.11.2	PROCESS FEED (-T PROC FEED)
172	6A	36.10.11.2	NOT PROC FEED (-T NOT PROCESS FEED)
173	6B	36.10.11.2	READ JAM (-T RD JAM)
174	6A	36.14.11.2	READ CHECK RESET (+T RD CK RESET)
175	6A	36.02.11.2	INTERLOCK STOP (+U INTERLOCK STOP)
176	6B	36.16.11.2	LAST CARD (-T LAST CARD OUT)
177	609850	36.16.11.2	51-80 COLUMN FEED FEATURE
178	3A	36.50.11.2	READ STACKER RESET (+T RD STACKER RESET)
179	6B	36.16.11.2	STOP KEY-ON (-T STOP KEY RP)
180	6B	36.19.11.2	START KEY (+U START KEY RP NO)
181	6B	36.01.31.2	NO 2 CL (-T 2 CL C)
182	6B	36.18.11.2	READ CHECK LIGHT (+U READ CHECK LIGHT)
183	6B	36.18.11.2	INVALID LIGHT (+U INVALID LIGHT)
184	6B	36.50.11.2	RD STACK MAG 1 (+U STACK 1)
185	6B	36.50.11.2	RD STACK MAG 2 (+U STACK 2)
186	4B	36.01.31.2	READ COMPLETE GATE (+T RD COMP GATE)
187	8A	36.10.21.2	SOLAR CB 2'ND RD (SC CB-2)
188	8A	36.10.21.2	SOLAR CB 1 ST CARD
189			
190			
191			
192	SPARE		
193	SPARE		
194	6B	36.50.11.1	STACK SELECT (-T STACK SELECT)
195			
196			
197			
198			
199	14A-B	56.15.11.2	+U TRANS READ BRUSHES
200			

P C CONNECTOR

1 /	2	3	4	5	6	7	8	9	10	11	12	13	14	15
01B7 E01A	01B7 E01B	01B7 E01C	01B7 E01D	01B7 E01E	01B7 E01F	01B7 E01G	01B7 E01H	01B7 E01J	01B7 E01K	01B7 E01L	01B7 E01M	01B7 E01N	01B7 E01P	01B7 E01Q
16	17	18	19	20	21	22	23	24	25	26	27	28	29	30
01B7 E01R	01B7 E02A	01B7 E02B	01B7 E02C	01B7 E02D	01B7 E02E	01B7 E02F	01B7 E02G	01B7 E02H	01B7 E02J	01B7 E02K	01B7 E02L	01B7 E02M	01B7 E02N	01B7 E02P
31	32	33	34	35	36	37	38	39	40	41	42	43	44	45
01B7 E02Q	01B7 E02R	01B7 F01A	01B7 F01B	01B7 F01C	01B7 F01D	01B7 F01E	01B7 F01F	01B7 F01G	01B7 F01H	01B7 F01J	01B7 F01K	01B7 F01L	01B7 F01M	01B7 F01N
46	47	48	49	50	51	52	53	54	55	56	57	58	59	60
01B7 F01P	01B7 F01Q	01B7 F01R	01B7 F02A	01B7 F02B	01B7 F02C	01B7 F02D	01B7 F02E	01B7 F02F	01B7 F02G	01B7 F02H	01B7 F02J	01B7 F02K	01B7 F02L	01B7 F02M
61	62	63	64	65	66	67	68	69	70	71	72	73	74	75
01B7 F02N	01B7 F02P	01B7 F02Q	01B7 F02R	01B7 F03A	01B7 F03B	01B7 F03C	01B7 F03D	01B7 F03E	01B7 F03F	01B7 F03G	01B7 F03H	01B7 F03J	01B7 F03K	01B7 F03L
76	77	78	79	80	1401 TERMINATION OF P C CABLE					81	82	83	84	85
01B7 F03M	01B7 F03N	01B7 F03P	01B7 F03Q	01B7 F03R						91	92	93	94	95
86	87	88	89	90						01A1 G11A	01A1 G11B	01A1 G11C	01A1 G11D	01A1 G11E
01A1 G11F	01A1 G11G	01A1 G11H	01A1 G11J	01A1 G11K						01A1 G11L	01A1 G11M	01A1 G11N	01A1 G11P	01A1 G11Q
96	97	98	99	100						101	102	103	104	105
01A1 G11R	01A1 G12A	01A1 G12B	01A1 G12C	01A1 G12D						01A1 G12E	01A1 G12F	01A1 G12G	01A1 G12H	01A1 G12J
106	107	108	109	110						111	112	113	114	115
01A1 G12K	01A1 G12L	01A1 G12M	01A1 G12N	01A1 G12P						01A1 G12Q	01A1 G12R	01A1 G13A	01A1 G13B	01A1 G13C
116	117	118	119	120						121	122	123	124	125
01A1 G13D	01A1 G13E	01A1 G13F	01A1 G13G	01A1 G13H						01A1 G13J	01A1 G13K	01A1 G13L	01A1 G13M	01A1 G13N
126	127	128	129	130	131	132	133	134	135	136	137	138	139	140
01A1 G13P	01A1 G13Q	01A1 G13R	01A1 G14A	01A1 G14B	01A1 G14C	01A1 G14D	01A1 G14E	01A1 G14F	01A1 G14G	01A1 G14H	01A1 G14J	01A1 G14K	01A1 G14L	01A1 G14M
141	142	143	144	145	146	147	148	149	150	151	152	153	154	155
01A1 G14N	01A1 G14P	01A1 G14Q	01A1 G14R	01A1 G15A	01A1 G15B	01A1 G15C	01A1 G15D	01A1 G15E	01A1 G15F	01A1 G15G	01A1 G15H	01A1 G15J	01A1 G15K	01A1 G15L
156	157	158	159	160	161	162	163	164	165	166	167	168	169	170
01A1 G15M	01A1 G15N	01A1 G15P	01A1 G15Q	01A1 G15R	SPARE	SPARE	SPARE	SPARE	SPARE	SPARE	SPARE	SPARE	SPARE	SPARE
171	172	173	174	175	176	177	178	179	180	181	182	183	184	185
SPARE	SPARE	01B4 D01R	01B4 D01A	01B4 D01B	01B4 D01K	01B4 D02A	01B4 D01E	01B4 D01F	01B4 D01G	01B4 D02F	01B4 D01C	01B4 D01H	01B4 D02B	01B4 D02C
186	187	188	189	190	191	192	193	194	195	196	197	198	199	200
01B4 D01J	SPARE	01B4 D01D	01B4 D02D	01B4 D02E	01B4 D02G	01B4 D01L	01B4 D01N	01B4 D01P	01B4 D02H	01B4 D02J	01B4 D02K	SPARE	SPARE	SPARE

PUNCH CONNECTOR WIRES (PC)

CONNECTOR POS (PC)	WIRE DIAGRAM LOC	LOGIC REF	DESCRIPTION
1 TO 80	14B	36.29.11.2	COL 1 TO 80 PUNCH MAGNETS (+U)
81 TO 160	13A-14A	42.40.51.1	COL 1 TO 80 PUNCH BRUSHES
161			
162			
163			
164			
165			
166			
167			
168			
169			
170			
171			
172			
173	14A	36.21.11.2	(-U LATCH RESET)
174	14A	36.21.11.2	(-T AFTER 9 CAM)
175	14A	36.21.11.2	(-T PCH SCAN CB)
176	4A	36.18.11.2	(-T PCH STOP)
177	12A	36.24.11.2	(-T PUNCH CLUTCH MAGNET)
178	12A	36.24.11.2	(-T PROCESS PUNCH)
179	12A	36.24.11.2	(-T NOT PROCESS PUNCH)
180	12A	36.24.11.2	(-T PUNCH JAM)
181	12A	36.14.11.2	(PU CHECK RESET PUNCH)
182	12B	36.24.11.2	DIE C L DELAY (-T PD CLD)
183	12B	36.50.11.2	(-T STACKER LATCH RESET)
184	12B	36.50.11.2	STACKER RELAY (+U STACK 4)
185	12B	36.50.11.2	STACKER RELAY (+U STACK 8)
186	SPARE		
187			
188	14A B	36.01.21.2	-T PD CLC
189	12B	36.50.11.2	STACK INHIBIT (+U STACK INH)
190	6B	36.18.11.2	(+U PUNCH CHECK LIGHT)
191	6B	36.19.11.2	(-T START RELAY)
192			
193			
194			
195			
196	14A	36.21.11.2	(-T BRUSH IMPULSE)
197			
198			
199			
200			

EXTERNAL POWER CABLES-1402 to 1401

R/P DRAWING	R/P CONNECTOR	FUNCTION	1401 TERMINATION		1401 DRAWING
11.01.11-2A	PWA - 1	133 VAC BULK SUPPLY	TB3-17	01B8	38.11.11-1A
	- 2	SPARE	TB1-1	01B8	31.11.61-11A
11.01.11-2A	- 3	133 VAC BULK SUPPLY	TB3-15	01B8	38.11.11-1A
11.01.11-1A	- 4	208 VAC #A TAPE DRIVE	TB1-2	01B8	38.11.61-11A
11.01.11-1A	- 5	208 VAC #B TAPE DRIVE	TB1-3	01B8	38.11.61-11A
11.01.11-1A	- 6	R/P FRAME GROUND	FRAME 1 BOND		38.11.61-11B
11.01.11-1A	- 7	208 VAC #C TAPE DRIVE	TB1-4	01B8	38.11.61-11A
11.01.11-2B	- 8	24 VAC COMMON	TB3-1	01B8	38.11.21-3A
	PWB - 1	SPARE	TB3-16	01B8	38.11.31-5A
	- 2	SPARE	TB3-9	01B8	38.11.31-5A
11.01.11-1A	- 3	EMERGENCY STOP	TB2-7	01B8	38.11.21-3A
21.00.11-18A	- 4	CARRIAGE MOTORS - 208 VAC	TB3-2	01B8	38.11.61-11A
21.00.11-18B	- 5	CARRIAGE MOTORS - 208 VAC	TB3-3	01B8	38.11.61-11A
21.00.11-18A	- 6	CHAIN & RIB MOTORS - 208 V	TB3-4	01B8	38.11.61-11A
21.00.11-18B	- 7	CHAIN & RIB MOTORS - 208 V	TB3-5	01B8	38.11.61-11B
	- 8	SPARE	TB3-14	01B8	38.11.31-5A
	- 9	SPARE	TB3-18	01B8	38.11.31-5A
	-10	+30V DIRECT	TB3-10	01B8	38.11.11-2A
11.01.11-1A	-11	POWER ON	TB3-11	01B8	38.11.21-3A
11.01.11-1A	-12	POWER ON	TB3-12	01B8	38.11.21-3A
11.01.11-1A	-13	208 VAC	TB1-6	01B8	38.11.61-11A
11.01.11-1A	-14	208 VAC	TB1-5	01B8	38.11.61-11A
11.01.11-2B	-15	CONV OUTLETS - 115 VAC	TB3-8	01B8	38.11.61-11A
11.01.11-2B	-16	115 VAC COMMON	115V BUS-1	01B8	38.11.61-11A
11.01.11-2B	-17	BLOWERS - 115 VAC	115V BUS-2	01B8	38.11.61-11A
	PWC - 1	-6 VDC FILTER DELAY	TB7-1	01B8	38.11.11-2A
21.00.11-17A	- 2	-60V CTRLD & SEQ - C R P	TB2-6	01B8	38.11.21-3A
11.01.11-2A	- 3	-12 VOLTS DC	TB2-1	01B8	38.11.61-12B
11.01.11-2B	- 4	-60V DC COMMON GROUND	GND BUS	01B8	38.11.61-12B
11.01.11-2B	- 5	-60V DC COMMON GROUND	GND BUS	01B8	38.11.61-12B
21.00.11-18B	- 6	CHAIN INTLK	TB2-3	01B8	38.11.61-12A
11.01.11-2B	- 7	+6V DC	TB2-5	01B8	38.11.61-12B
21.00.11-18A	- 8	SPACE MAGNET OFF	TB2-4	01B8	38.11.61-12A
11.01.11-2A	- 9	-20 V DIRECT	TB2-15	01B8	38.11.61-12A
	PWD - 1	-20V SEQ	TB2-14	01B8	38.11.61-12A
11.01.11-2B	- 2	-60V SEQ PRINTER MAGS	-60V BUS	01B8	38.11.61-12A
	- 3	SPARE	NONE		38.11.31-5A
11.01.11-2A	- 4	DC COMMON GROUND	GND BUS	01B8	38.11.61-12B
	- 5	SPARE	TB7-5	01B8	38.11.31-5A
	- 6	SPARE	NONE		38.11.31-5A
11.01.11-2B	- 7	-60V SEQ PRINTER MAGS	-60V BUS	01B8	38.11.61-12B
	- 8	SPARE	TB7-2	01B8	38.11.31-5A
11.01.11-2B	- 9	-20V SENSE CONTROL	TB2-16	01B8	38.11.21-4A
11.01.11-2B	-11	POWER OFF	TB7-3	01B8	38.11.21-4A
11.01.11-2B	-12	PRINTER INTLK CTRL - 1	TB2-9	01B8	38.11.21-4A
11.01.11-2B	-13	PRINTER INTLK CTRL - 2	TB2-10	01B8	38.11.21-4A
21.00.11-18A	-14	SKIP MAG OFF RELAY INTLK	TB2-11	01B8	38.11.61-12A
11.01.11-2B	-15	SPACE MAGNETS	TB2-12	01B8	38.11.61-12A
11.01.11-2A	-16	-20 VOLTS DC DIRECT	TB2-13	01B8	38.11.21-3A
	-17	SPARE	TB7-4	01B8	38.11.31-5A
	-18	SPARE	TB7-6	01B8	38.11.31-5A

FUSES

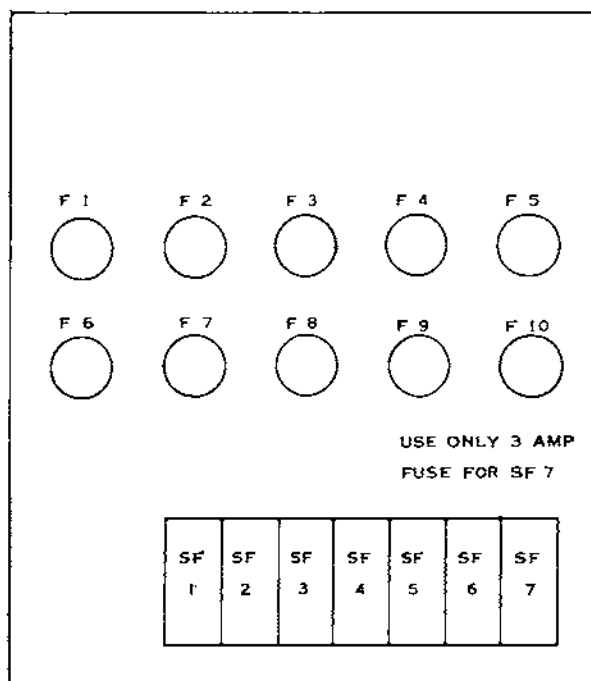

AC FUSES

<u>No.</u>	<u>Loc.</u>	<u>Type</u>	<u>P/N</u>	<u>Circuit</u>
1	1A	FNM10	107669	1250W Bulk Supply
2	1B	FNM5*	107666	-60 V Resonant Supply
3	1B	FNM3,2	107664	Reader Motor
4	1B	FNM3,2	107664	Punch Motor
5	1B	FNM10	107669	115 VAC Supply (to conv. outlets & blower motors)
6	1B	BAF1	107799	Dynamic Timer
7	2B	FNM8	107668	1401 Blower Motors (output of 115 VAC supply)
8	2B	FNM8	107668	Convenience Outlets (from 115 VAC supply)
9	1A	BAF1	107799	24 V Transformer (to power-up circuits)
10	2A	FNM0.6	252590	3 V Buck-Boost Supply

DC FUSES (-20 Volts)

<u>No.</u>	<u>Loc.</u>	<u>Type</u>	<u>P/N</u>	<u>Circuit</u>
SF-1	3A	GLD5	104909	Read Feed & Card Lever Relays
SF-2	3A	GLD5	104909	Reader Run & Motor Control
SF-3	9A	GLD5	104909	Punch Feed & Card Lever Relays
SF-4	11A	GLD5	104909	Punch Clutch & Punch Stop Circuits
SF-5	14B	GLD5	104909	-20 Volts to Punch Magnets
SF-6	5A	GLD5	104909	Start Key & Interlock Stop
SF-7	2A	GLD3	253675	-20 Volts Direct & Sequenced to 1401

* Use FNM10 fuse 107669 and 20A power supply with Numeric Chain Printer.

-60 VOLT SUPPLY

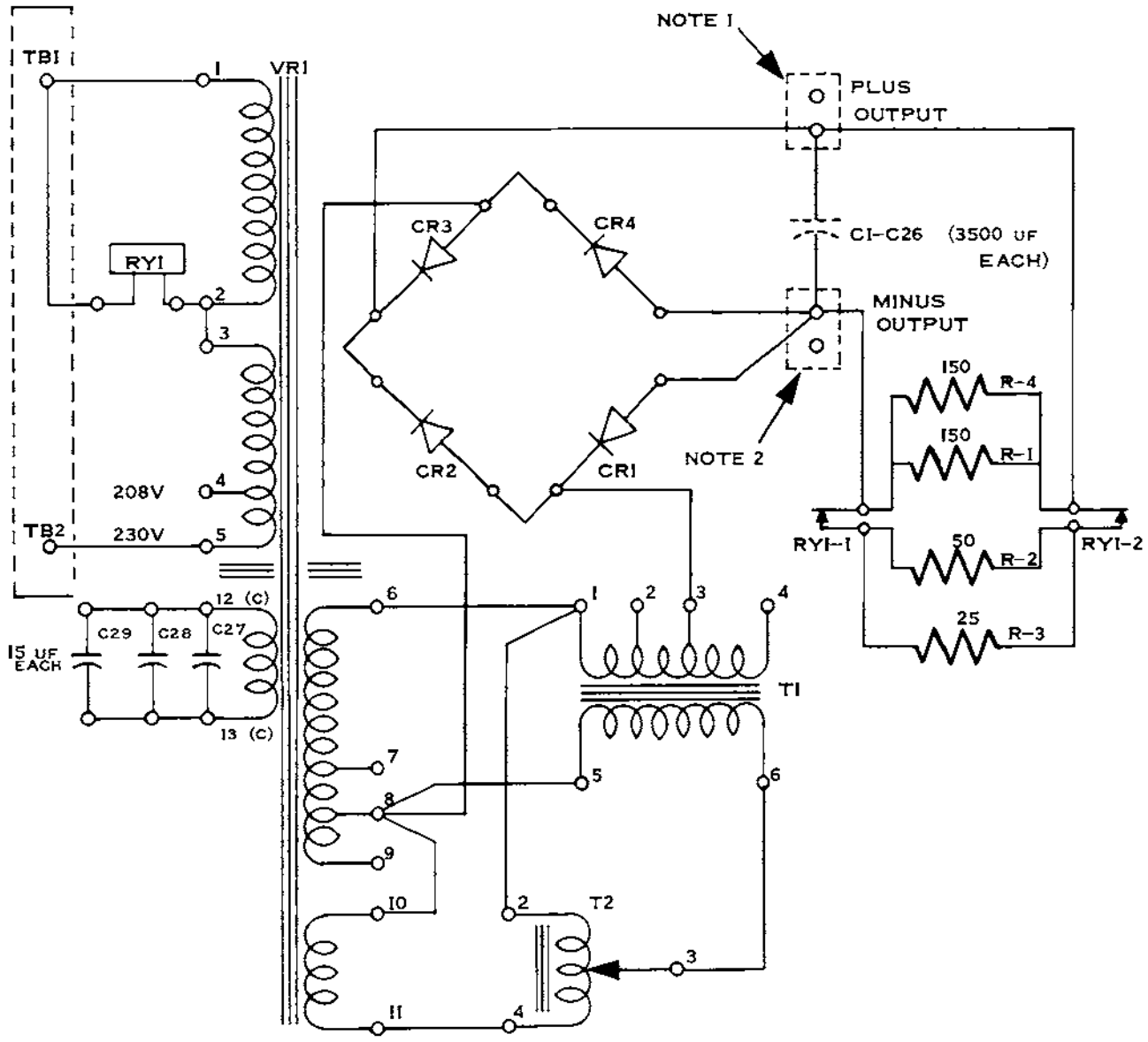

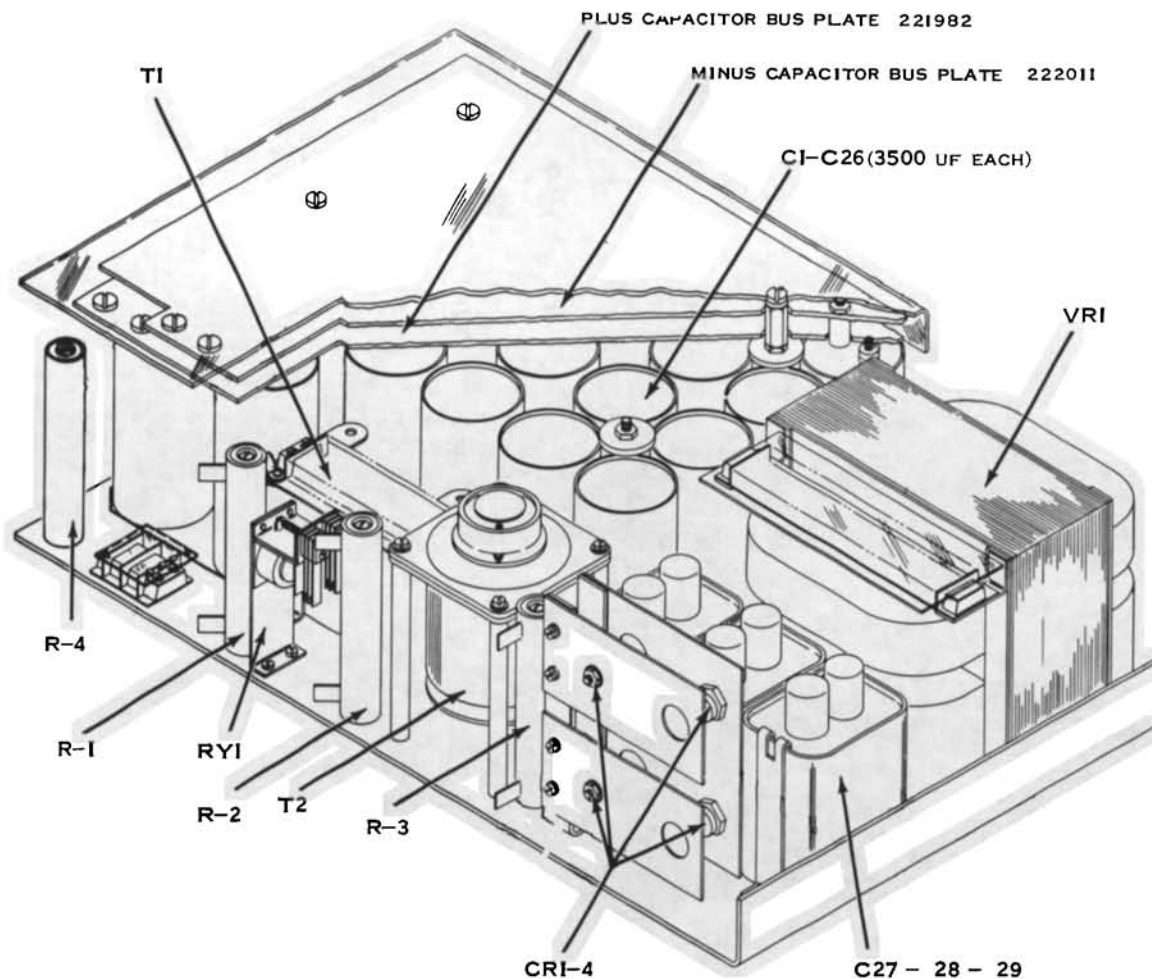

NOTE 1 + CAPACITOR BUS PLATE PART NO. 221982
 NOTE 2 - CAPACITOR BUS PLATE PART NO. 222011

PHYSICAL LOCATIONS — 60 VOLT SUPPLY



POWER SUPPLY SERVICE HINTS

- 1 If voltage is missing, check AC fuse 2 (see fuse chart, page 1-9).
- 2 Check for loose terminals. Low output can cause intermittent printing problems.
- 3 Visually inspect cables for chafing and pinch points.
- 4 An open diode in the rectifier circuit will show up as low voltage under load. Output voltage ripple will look like  When operating correctly, the voltage ripple should look like this  When operating normally, the diodes will feel quite warm to the touch. An open diode will be cold to the touch.
- 5 Diodes should be removed from the circuit for checking resistance.
- 6 When isolating troubles with the 60 volt supply, do not overlook relay HD-9 in the transformer primary circuit.
- 7 The new style 60 volt supply which has resistor 4 can present a burn hazard. A large metal shield is available to prevent this hazard (see 1402 E/C CEM 89).

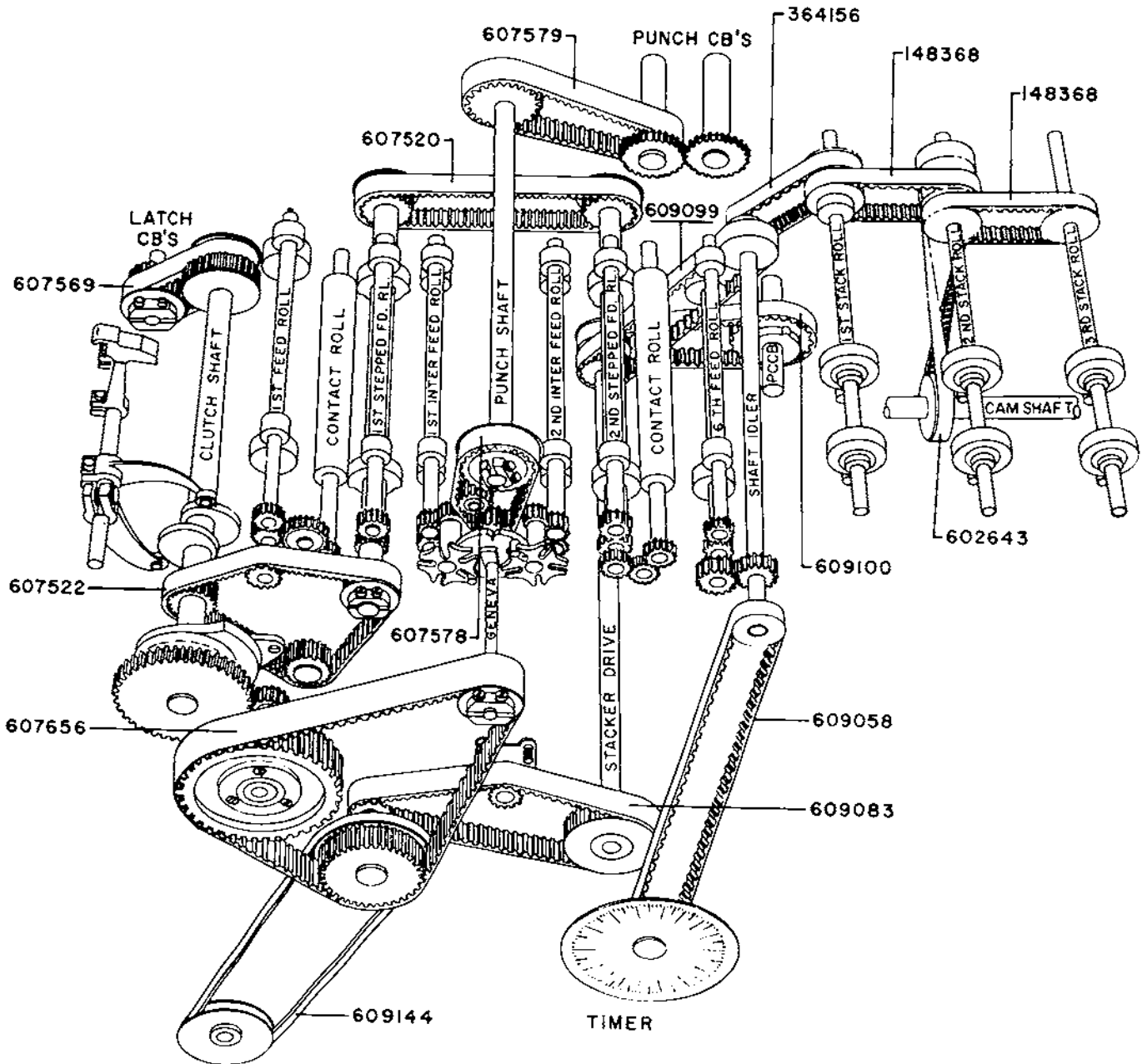
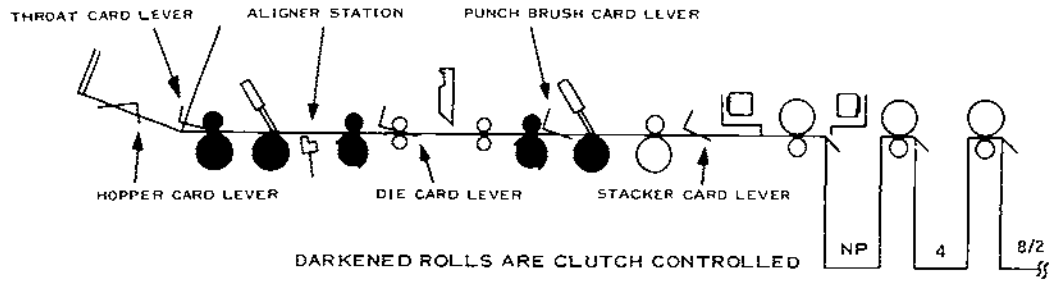

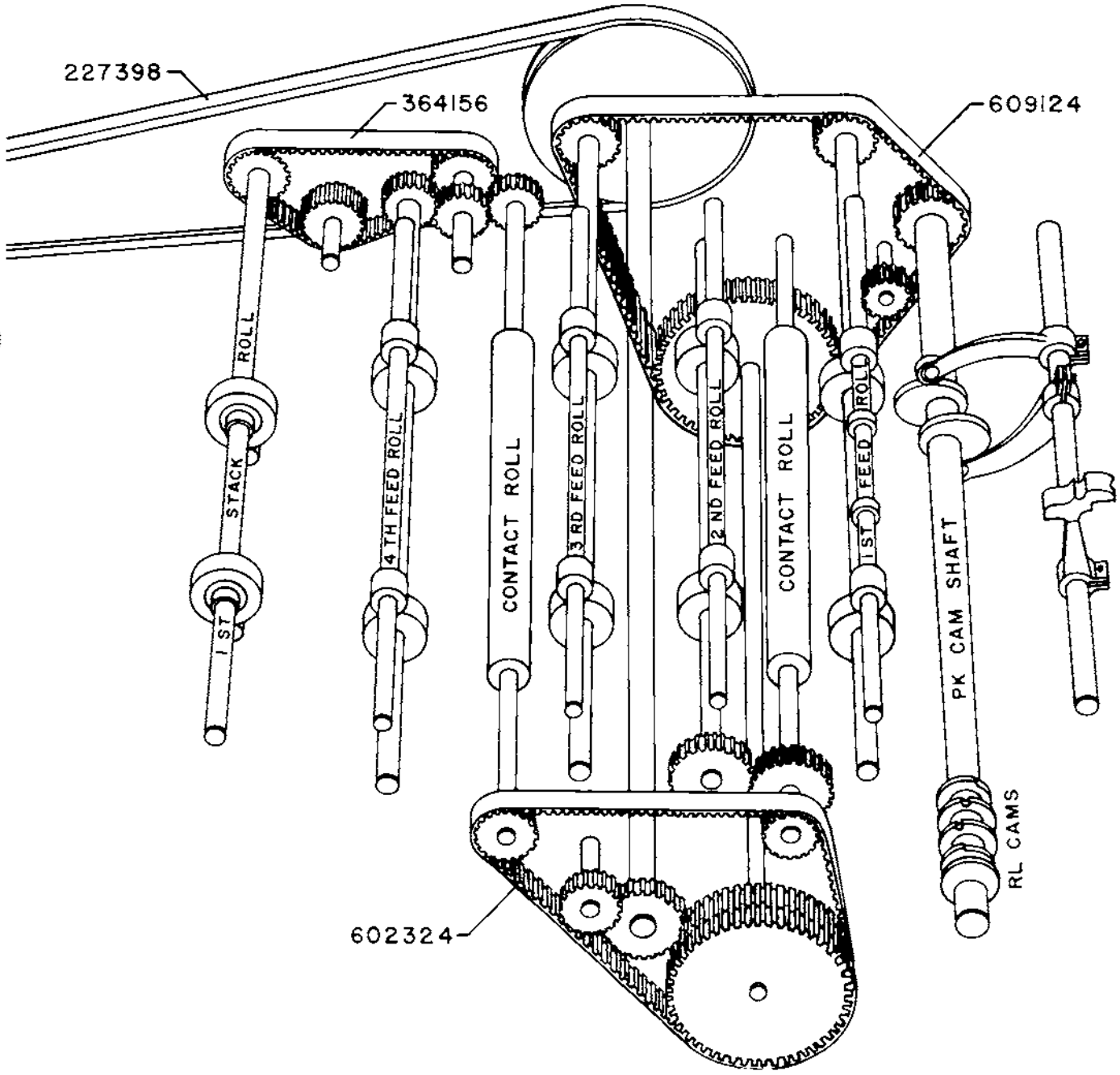
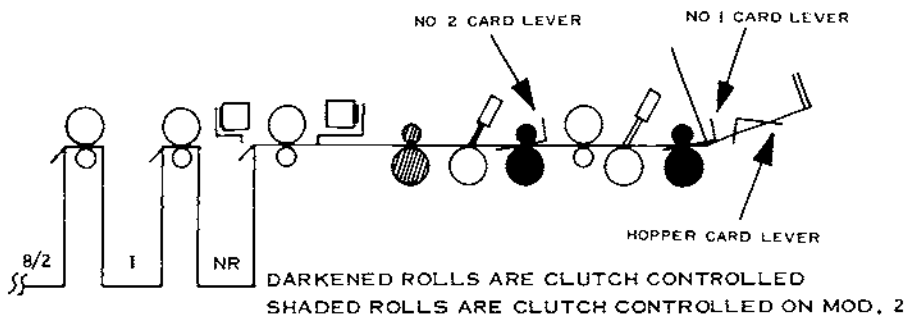

READER STOP

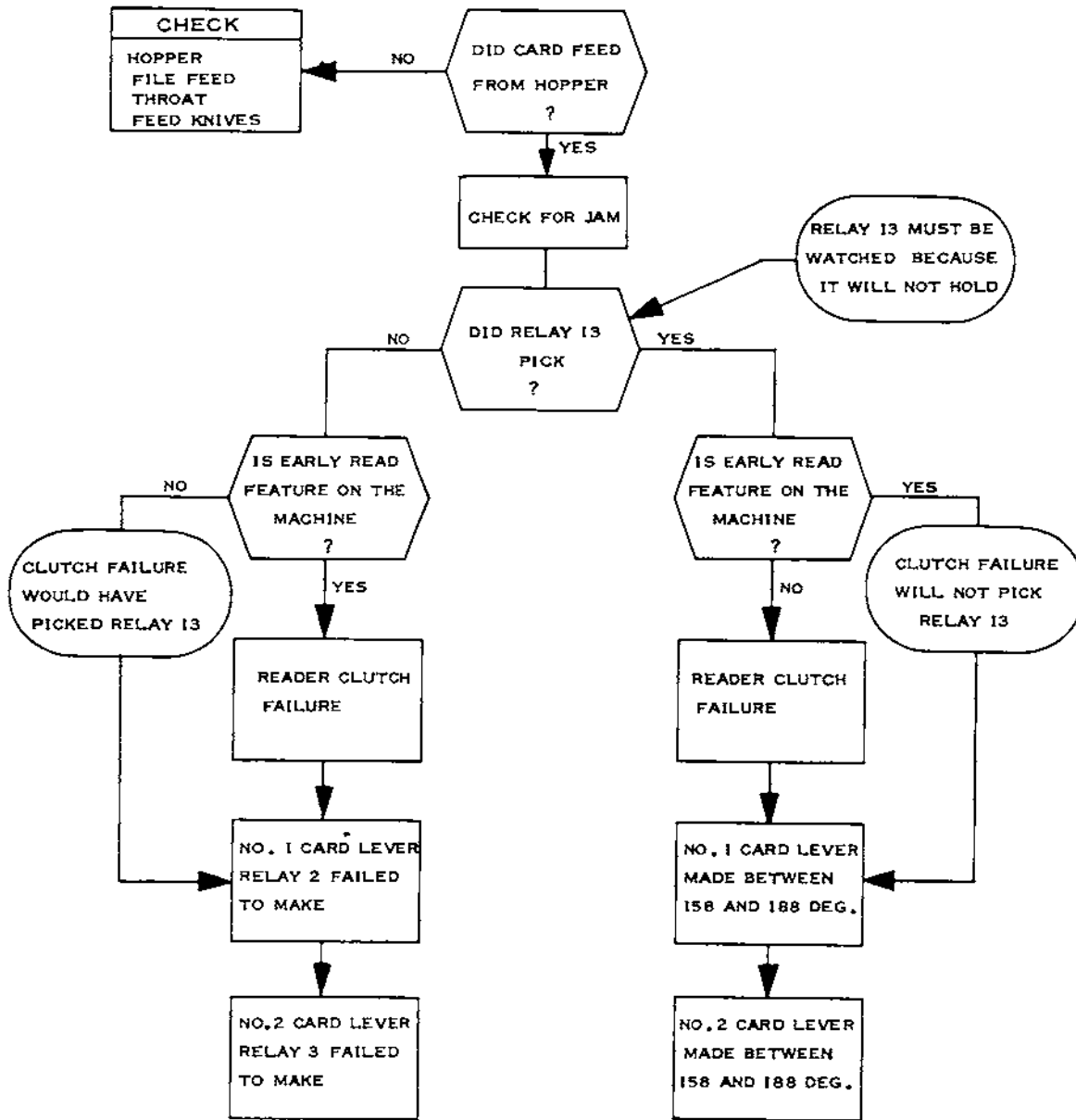

ISOLATE CIRCUITS BY REMOVING WIRES TO LOCALIZE FAILURE

READER STOP SERVICE HINTS

CARD FEEDING FAILURES

- 1 Check hopper end posts and side plates.
- 2 Check feed knives; make sure they are parallel, they do not bind, and they get behind the cards .020 to .030.
- 3 Check throat adjustment.
- 4 Check that hopper card lever does not raise card off feed knives.
- 5 Check that proper amount of cards are in hopper (at level of sensing pads).
- 6 Check front and side jogglers . (Refer to Reference Manual for correct file feed adjustments.)

READER STOPS DUE TO CLUTCH OR CHECK CIRCUITS

- 1 No clutch cycle when R-10 is picked.
- 2 Clutch cycle when R-10 is not picked.
- 3 Slow dropout of R-10, check dynamically.
- 4 Mechanical clutch failures--failure to unlatch, failure to latch, and failure to engage due to the dog bouncing out of the ratchet.
- 5 Clutch magnet CB - The timing of this CB is critical. Its tolerance of +0 -2 must be maintained to insure proper relationship of the dog to the ratchet. (Refer to Clutch section, page 2-4).

CARD LEVER FAILURES

- 1 Check card levers for sufficient rise.
- 2 Check card levers for burning, loose points, and bounce. Card lever timing is critical and should be checked with the dynamic timer.
- 3 Check pick and hold of card lever relays dynamically. Also check actual transfer time of relay points. (Refer to 1402 E/C CEM 86.)

PROCEDURE FOR DETERMINING EXTRA OR MISSING CLUTCH CYCLES WITH 310 SCOPE

Sync scope on read feed trigger turning on. (Logic 36.10.11) Adjust sweep speed to display one machine cycle and probe impulse CBs. For an extra cycle, there will be a blip on the left edge of the scope caused by the impulse CBs; but there will not be a sweep. For a missing cycle, there will be a sweep; but the impulse CBs will not be displayed. For the condition where the clutch unlatches but the dog does not seat, the impulse CBs will be displayed at the extreme right of the scope face.

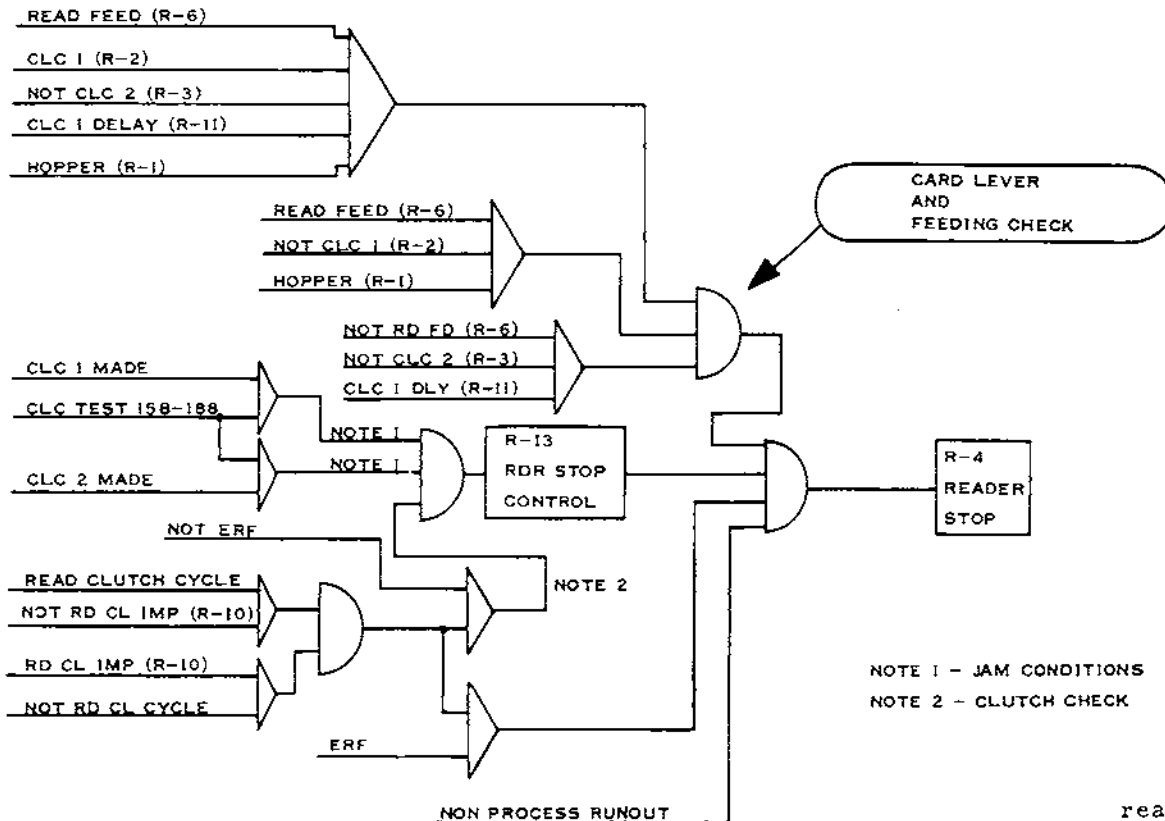

READER CLUTCH

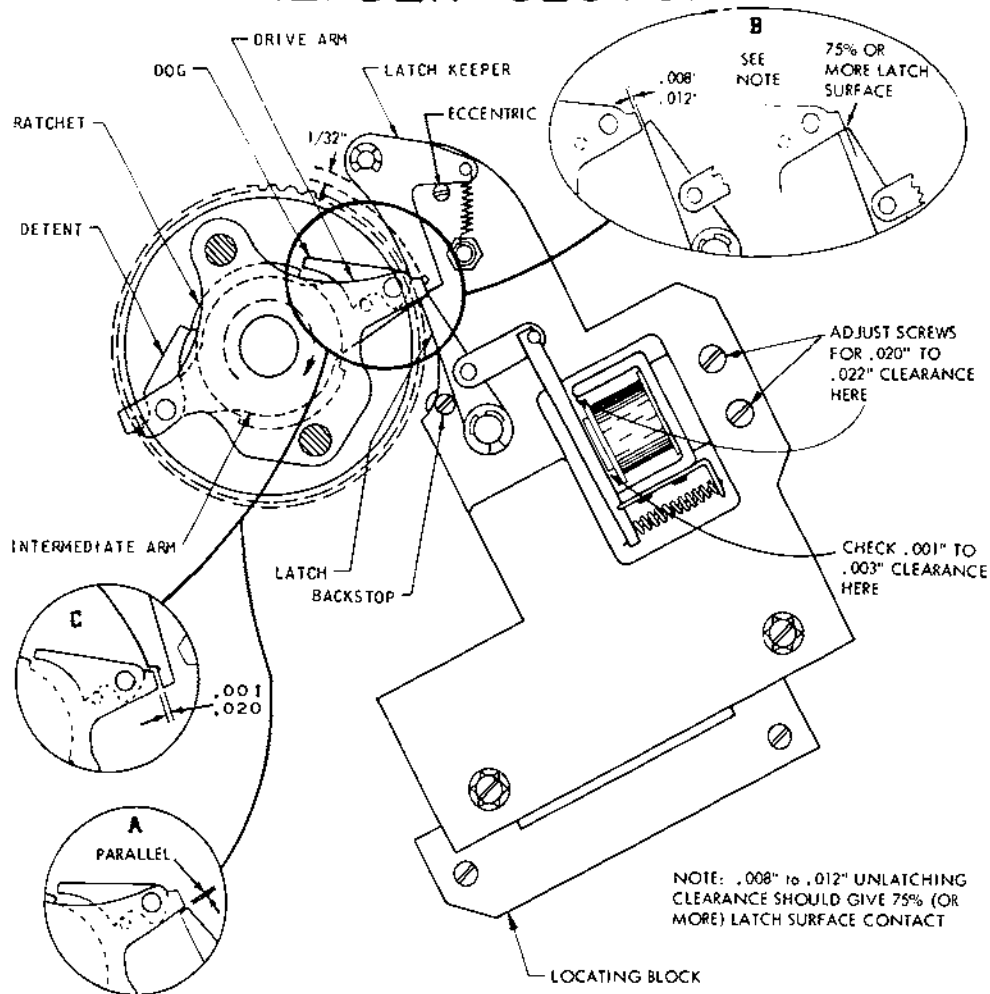

PRINCIPLES OF OPERATION

Impulsing the magnet releases the latch and allows the intermediate arm to move in relation to the drive arm. The intermediate arm moves clockwise due to the spring-loaded dog and detent exerting force on the control studs. As the intermediate arm moves, the dog and detent are allowed to engage the ratchet and rotate the mechanism that drives the feed knives and controlled feed rolls.

Unless the clutch magnet is again impulsed, the clutch will disengage when the opposite end of the arm strikes the latch. The intermediate arm, having moved clockwise in relation to the drive arm, will strike the latch first. The drive arm continues to move, and in so doing, causes the dog and detent to be cammed away from the ratchet by the motion of the pivot studs with reference to the control studs on the intermediate arm. Inertia carries the drive arm forward to strike the latch, and the keeper falls behind it to hold the clutch latched at 315° .

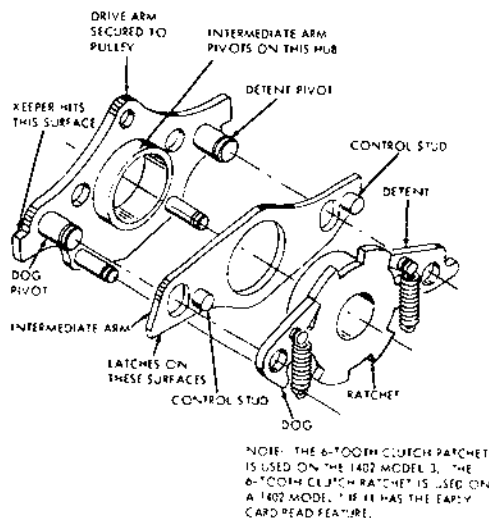

CLUTCH ADJUSTMENTS

The read clutch may be adjusted in the machine or with the clutch drive unit removed from the base. Steps 1 thru 4 should be performed when a new clutch assembly is installed or when complete adjustment of the center plate assembly must be made. When this is necessary, the read clutch locating gauge #610147 must be used. (Using this tool will insure a parallel condition between drive arm latch surface and the latch at latch-up time.)

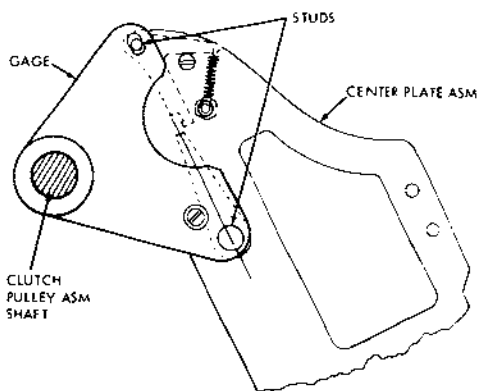

- 1 Remove clutch pulley assembly.
- 2 Remove latch keeper and latch from center plate assembly.
- 3 Position locating gauge on center plate assembly studs and clutch pulley assembly shaft with positioning block loose. Secure positioning block against bottom of center plate assembly as far left as possible. Remove gauge.
- 4 Reinstall latch keeper, spring, latch, and pulley assembly.
- 5 Adjust armature pivot bracket to maintain .001" to .003" clearance between armature and core.
- 6 There should be .020" to .022" clearance between armature and yoke with latch against backstop.
- 7 Hold armature attracted and at same time remove slack from linkage by pushing latch toward drive arm. Position center plate assembly on positioning block to get slight drag on .008" feeler gauge between latch and clutch drive arm. Tighten center plate assembly mounting screws. There should be at least 75% of latch contacting drive arm assembly in latched condition.
NOTE: Be sure to keep center plate against positioning block.

- 8 Loosen positioning block mounting screws and position block as far right (ear of locating block against plate) as possible. Lock mounting screws.
- 9 Adjust center eccentric keeper stop stud to obtain .001" to .020" between clutch drive arm and latch keeper at latch time.
- 10 Check for .002" clearance between step on ratchet and detent (backlash) with clutch engaged. If there is more than .002" clearance, replace with longer detent.

NOTE: Seven new detents, 609737 through 609743, are available. These detents are etched 1 through 7. Each detent is .002" longer than the preceding one.

SERVICE HINTS

The following parts must be used on machines with the early read feed feature.

615469 CLUTCH LATCH ASSEMBLY
603729 CLUTCH ASSEMBLY

When replacement of parts on the old style clutch is required, B/M 605435 which replaces the entire clutch and latching mechanism should be used (ref: 1402 E/C CEM 24).

Clutch failures fall into two categories, failure to latch and failure to unlatch. An extra cycle or a missing cycle may be due to the dog bouncing out of the ratchet. If you suspect trouble in this area, enter a program in the 1401 to cause intermittent feeding; then watch and listen to the clutch. If the clutch fails, you will usually be able to hear it.

Cleanliness and proper lubrication are essential to the proper operation of this clutch.

One possible cause of extra cycles is wear in the armature which can allow the armature to seal on the core.

On a reader stop caused by a clutch failure, the last card in the stacker may have failed to read in. This appears as if the clutch failed to latch, but it just as well may have failed to engage. If the dog misses a tooth, a reader stop will result; but the dog will still fall into the next tooth and the clutch will take a cycle.

READ CHECKS

IF READER STOP CONDITION IS ALSO PRESENT FIND AND CORRECT IT FIRST.

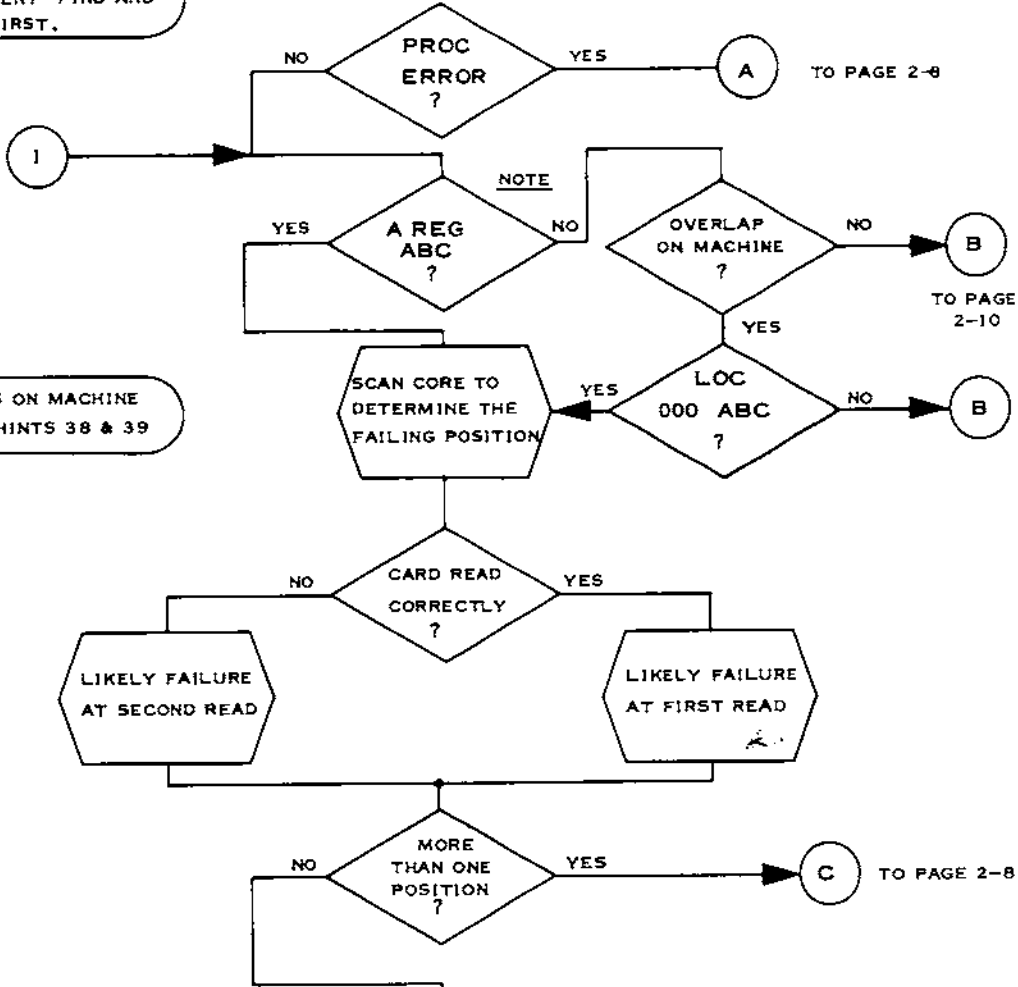

IF OVERLAP IS ON MACHINE SEE SERVICE HINTS 38 & 39

NOTE - IF CUSTOMERS PROGRAM IS IN THE MACHINE - BE SURE THAT THE PROGRAM STOPPED IN A READ OP BEFORE CHECKING FOR AN A REGISTER ABC.

CHECK	
1ST & 2ND READ BRUSHES	SH 1 - 5
CONTACT ROLLS	SH 2 - 4
PFR RELAYS	SH 5
RC CONNECTORS	SH 5
ROW BIT RESISTOR	SH 3

C
TO PAGE 2-8

READER CHECK
(PART 1 OF 3)

READER CHECK SERVICE HINTS

- 1 If a failure reappears in one position, do not hesitate to replace both first and second read brushes. It is possible for a brush to read into core correctly and still cause a reader check.
- 2 Make sure that contact rolls are clean and free from correction stickers. Some types of cards have been known to cause a buildup of ink on the contact rolls causing a reduction of current to the row bit cores. Check for contact roll wear.
- 3 On full write machines the 180 ohm resistors in series with row bit cores and brushes may increase in resistance. If reader checks are being encountered with cards having the same digit punched in many columns, check the resistors. Replace if the value exceeds 189 ohms. (330 ohms on half write machines)
- 4 Make certain that the contact rolls are tight and that the belts are in good condition.
- 5 To test the circuit from a brush through its associated row bit winding, remove the brush block and check for -20 volts on the brush.

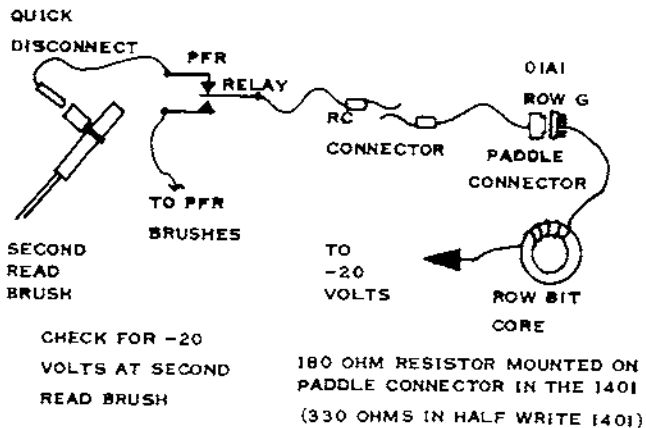

- 6 To determine what is being read from 1st read, the RD 1 and RD 2 impulses may be switched in the 1401 by extending the edge connector at 01A3A24, logic 35.15.51, and reversing the 2 lines. This causes the 1st read brushes to enter core.

- 7 The RL CBs should be clean, and the tension adjusted to approximately 200 grams to eliminate all bounce. Tension should be adjusted by disassembling the contact pile and forming the operating strap at the bend. Always scope the make and break of the CB after adjusting to make certain that all bounce has been eliminated (ref: 1402 S/A CEM 3).
- 8 For optimum machine operation, set the impulse CBs for a duration of 2° to $3 \frac{1}{2}^{\circ}$ after one hour operation.
- 9 Bit pickup in columns 1-5. Can fail on blank cards. Sometimes trouble will stick to one particular bit.
CAUSE - Impulse CB timing or bounce.
- 10 Silver point CBs P/N 610070 are available for use in positions RL 1-2-3-4 & 9. These CBs have lower resistance and better bounce characteristics. Do not use the silver CBs in other positions. Heavier current in the other circuits will cause early failure of the silver contacts (ref: 1402 E/C CEM 77).
- 11 Process errors will not stop the machine on an I/O operation until the end of the operation. If it is desired to stop at the time of the error to observe the failure condition, wire process error to delta process reset. (For overlap machines, wire process error to clock stop.)
- 12 Adjust brushes to scribed line per page 2-16. If brush timing is off, change picker knife timing to get correct brush timing.
- 13 To check for short brushes or brush block skew, check brush timing with the PC and RC connectors in place. This effectively places all the brushes in parallel and allows them to be simultaneously displayed on the timer. To display any one brush, use a card with one column punched. This card can be easily punched on the 1402.
- 14 Intermittent reader checks and setting extra bits in address 0001 can result from a slow fall time of the read brush impulse. This problem exists only on 1402s with solar CBs. B/M 605455A corrects this problem by delaying read scans. (B/M 605455A applies to machines with "M" wiring diagram suffix.)
- 15 Hardened 2 group brushes P/N 609798 and brush block P/N 610275 are available for use in 1402 Mod I. (For brush usage on other 1402s, ref: 1402 E/C CEM 78).

READ CHECKS

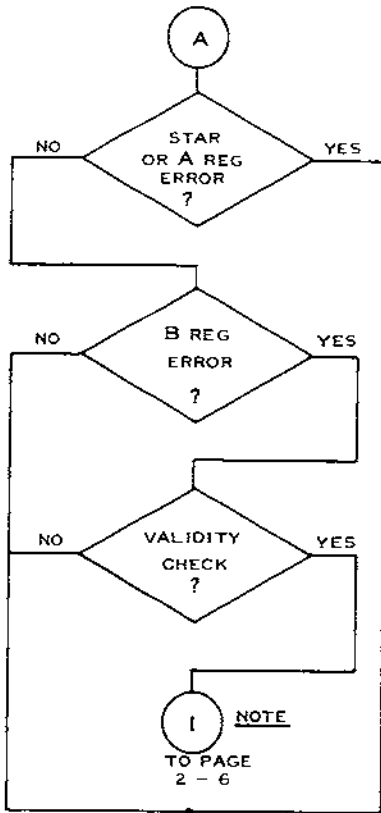

READER CHECKS SHOULD NOT CAUSE PROCESS ERRORS, EXCEPT FROM A B REG ERROR OR STORAGE ERROR CAUSED BY A VALIDITY CHECK. PROCESS ERRORS ARE USUALLY CAUSED BY I40I FAILURES OR BY NOISE GENERATED IN THE I402. PROCESS ERRORS SHOULD BE CORRECTED FIRST.

NOTE— SHOOT READER CHECK

READER CHECK
(PART 2 OF 3)

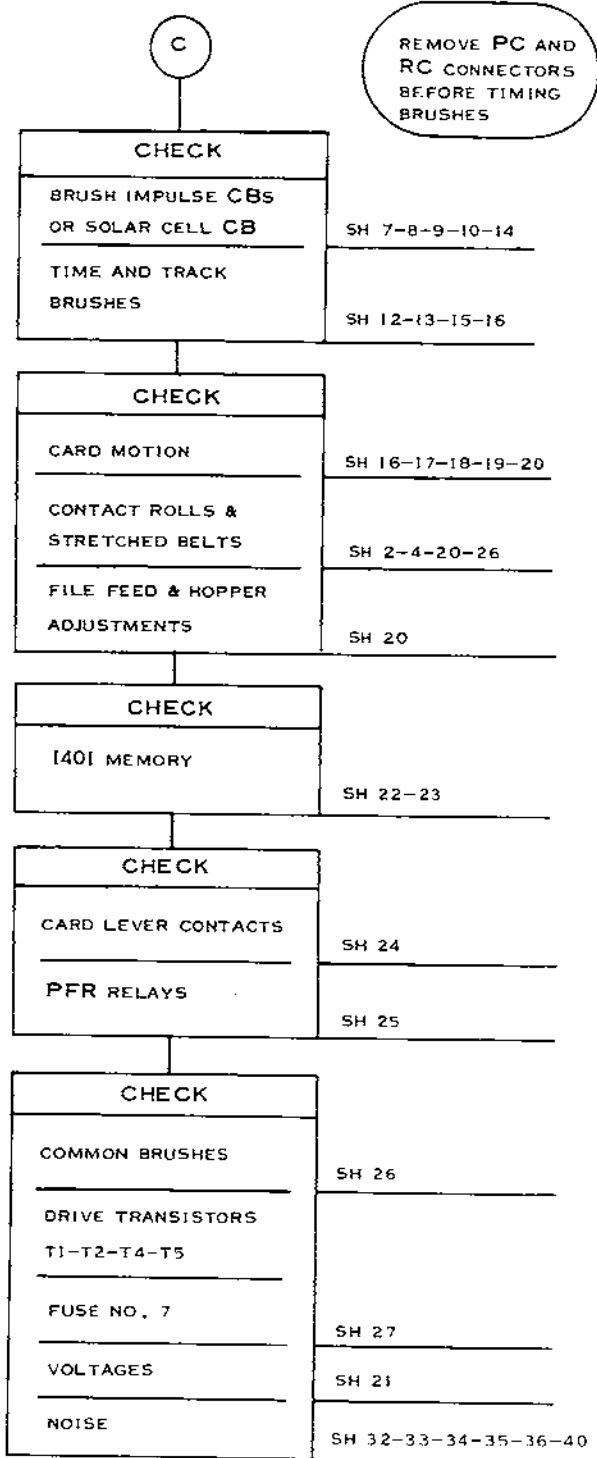

- 16 Observe the brush impulse CBs on the dynamic timer with intermittent clutch operation. Any variation or bounce in the impulse indicates a stretched belt, loose pulley, or defective clutch.
- 17 Check read feed rolls for uneven pressure. Pressure should measure 6 pounds on a strip of card when drawn through any single set of feed rolls.
- 18 Reader checks and false read-in of 9's can be caused by failure of card to arrive at second read contact roll in time. Check card feeding.

19 Check that the speed of the machine is 800 cpm plus 3 minus 20.

20 Reader checks may be caused by erratic card feeding. To check for this condition, scan no-op's through core, put a read op in lower core, and put a branch back in upper core to cause intermittent clutch operation. Observe the brush timing and the leading and trailing edge of the card on the dynamic timer for any variation. Check the following:

FEED KNIVES

Wear, binding, getting behind card, loose inserts

THROAT

Adjustment, wear, binding roller

BELTS

Cracked, stretched, worn, broken

HOPPER

Loose front joggler mounting bar, card lever, rear post to card clearance, side plates, deformed deflector springs

CLUTCH

Adjustment, cleanliness, lubrication, binds, wear, broken

CONTACT ROLLS

Loose, worn or loose pulleys, clearance to separator

CARD WEIGHT

Deformed springs (replace) (ref: 1402 S/A CEM 7)

FEED ROLLS

Wear, flat spots, tension, loose keyway, binding hangers

21 With carbon contact rolls, it is possible to fail to set a row bit core unless the -20 volt supply is set at -21 volts (ref: 1402 E/C CEM 56).

22 A 1401 memory failure may appear as a reader check. Switch the sense amps for the RD 1 - RD 2 and check planes to a bit line to determine if the failure is in this area. The current source and driver cards are also a possibility and should be eliminated by substitution. Any memory failure may show up as a single or multiple position failure.

23 If you storage scan after a false read or punch check and the 1401 does not stop on any error position, suspect check plane trouble. If the 1401 fails to write into or read out of the error check planes, you will get false read checks when reading 12's and false punch checks when punching 9's.

24 Intermittent reader checks can be caused by bouncing card levers or card lever contacts with loose points.

25 Dropping of 9's on a read operation following a PFR operation is caused by slow dropout of relay 59. Check PL 17 for a 282° break (ref: 1402 E/C CEM 42).

26 Adjust contact roll common brush for minimum resistance. Connect ohm meter between common brush and read brush and measure resistance with machine running.

27 Intermittent reader checks may occur if the mounting clips for fuse #7 are loose. Also, do not overlook the possibility that fuse #7 is blown but has failed to indicate, or you may have a high resistance fuse.

28 To operate 1402 read feed without cards--

- tape down hopper card lever.
- close first and second card lever contacts.
- raise first and second read brushes from contact roll.
- remove wire from relay 13 pick.
- enter a short read loop in storage.

"A" register setup, read scans, etc. can be scoped without handling cards.

READ CHECKS

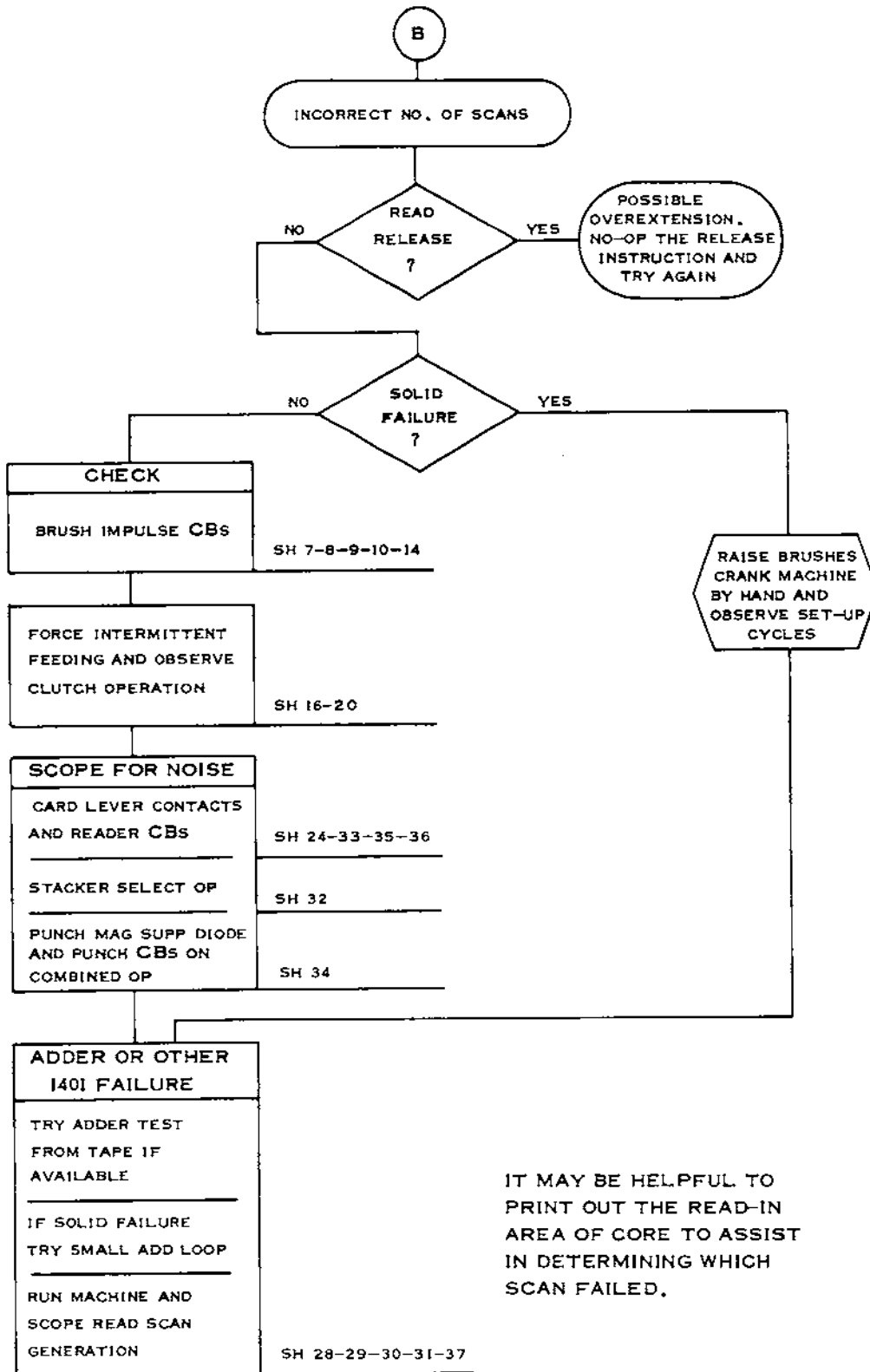

READER CHECKS
(PART 3 OF 3)

- 29 When cranking machine over by hand, raise the brushes and do not let machine set for long periods of time to prevent core damage. Make certain that the clutch is detented before running machine.
- 30 A sync for any given scan can be developed from the output of the A Reg combined bits, logic page 35.16.51 thru 35.16.81. A sync for scans 2 thru 7 can be taken from the sense switches on logic 34.22.11.
- 31 A reader check with the "A" register at 3 or 4 on half write machines may be caused by diodes RD 86 or RD 87 having a high forward resistance. A defective diode will result in a scan every other digit time (ref: W/D page 11.04.11.1).
- 32 A .47 MFD capacitor has been added between RC 6 stationary and RC 1 operating contact to reduce stacker select noise (ref: 1402 E/C CEM 18).
- 33 A RC network has been added to the first and second read card lever relay pick coils to eliminate noise spikes (ref: 1402 E/C CEM 57).
- 34 When performing a combined read-punch operation, noise from the punch magnets can cause reader checks. Check for an open PMT suppression diode. A resistor has been added to the PMT noise suppression circuit to reduce noise spikes (ref: 1402 E/C CEM 85).
- 35 To determine if noise is causing your reader check problem, you may ground the RD common to the machine frame. This will appreciably decrease the overall noise level of the machine.
- 36 Some possible sources of noise in the 1402 are CBs, collapsing relay coils, select magnets, punch magnets, card levers, motor start contacts, open suppression circuits, and input line noise (ref: 1402 E/C CEM 93). Probe DC voltages at CE panel and try to relate the noise to type of operation being performed.
- 37 Some troubles caused by the adder are simpler to find on an add operation. Run the 1401 adder tests.

- 38 To prevent O to A transfer on overlap machine and to keep scan count in A reg, turn tape select switch to any number.
- 39 Turn rotary switch on 1401 lower console to R/P off position to eliminate overlap mode.
- 40 Refer to noise page 2-20.
- 41 Install new contact roll assembly.

The bearing hubs should be located in a horizontal position with the flat side up so the brush block will seat properly without bending.

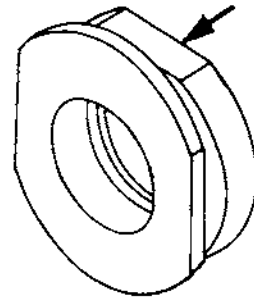

- 42 Bronze contact rolls are wax impregnated. When all wax has left bronze contact rolls, highly intermittent read failures may occur at any digit or column. Contact rolls with no wax remaining should be replaced.

SOLAR CELL CB

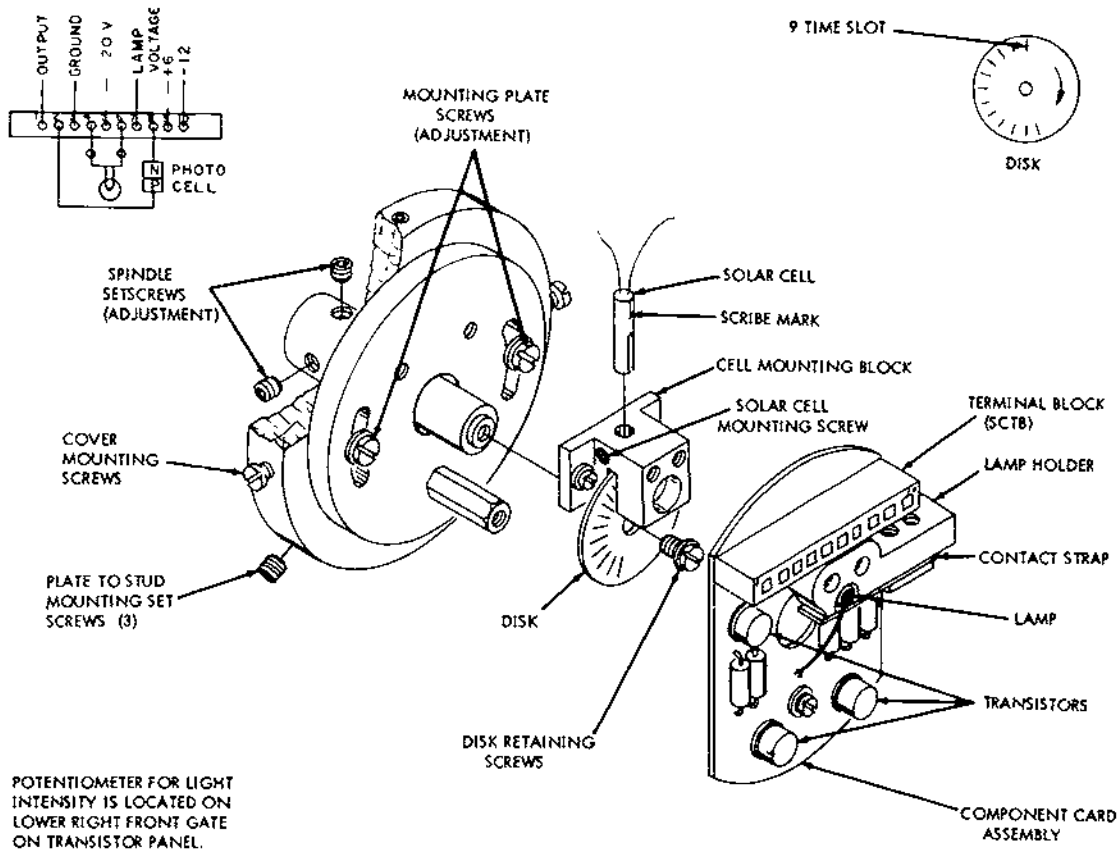

The solar cell circuit breaker has one mechanical moving part which is the disk. The disk has 12 timed slots in it (9 through 12 time). As the disk revolves, the slots in the disk allow the light beam to strike the solar cell at digit impulse time. When the light strikes the cell, transistor T6 is conditioned by the cell output. The output of T6 is amplified by T7 and then T8. The output of T8 is used to condition 1401 and 1402 circuitry just as the digit impulse RLCBs did prior to the solar cell. The pulse duration of the solar cell CB varies with the light intensity while the pulse timing varies with the relationship of the slotted disk to the light beam.

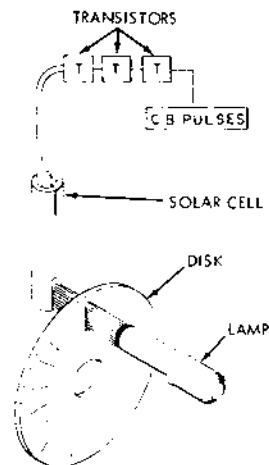

TIMING PROCEDURE

First obtain a coarse timing by aligning the 9 slot opposite the light source at 9 time. Then check the timing dynamically at several digit times and rotate the CB mounting plate to obtain correct timing.

ADJUSTMENT PROCEDURE

- 1 Check for the disc being visually centered in the slot. Adjust if necessary by loosening set screws and repositioning spindle on picker knife shaft.
- 2 Set the potentiometer to give 1.8 volts across the lamp terminals (SCTB 4 & 6). This is an initial setting; the final setting will result in a pulse duration of 2 to 3 degrees while reading cards.
- 3 Remove machine power and unplug solar cell leads at SCTB 2 & 8. Place solar cell across meter with a setting capable of measuring 0 to 500 microamps (yellow lead plus).
- 4 Bring up power and hand crank machine to a point where the timing disk allows light to fall on the solar cell. Position solar cell and/or light bulb to obtain maximum output (should be 100 microamps or more).

SERVICE HINTS

CAUTION - Damage to the solar cell emitter circuits can result from improper operation of the dynamic timer. While using the dynamic timer in the CB display mode, the outer light of the dynamic timer must not be activated from an external source.

SERVICE HINTS

If you find it difficult to obtain the required output from the solar cell, check to be sure that the light bulb is properly seated in the mounting block.

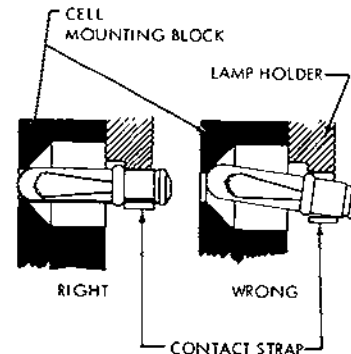

The duration of the CB impulses should always be checked under load conditions (reading cards).

The 1.8 volts across lamp terminals SCTB 4 & 6 is only an initial setting; and if the 100 microamps cannot be achieved but the pulse duration of 2 to 3 degrees can, there is nothing to be concerned about except you possibly will be running at the limits of the potentiometer and may eventually have to replace the light bulb.

ON MACHINES WITH SOLAR CB, IT IS EXTREMELY IMPORTANT THAT FUSE #7 BE A 3 AMP FUSE.

If the 1401 does not control the 1402 feeding, it is likely the solar CB is inoperative.

IF YOU ARE EXPERIENCING INTERMITTENT BLOWING OF FUSE #7, DO NOT HESITATE TO REPLACE THE SOLAR CB CARD AS IT IS THE MOST LIKELY CAUSE.

SOLAR CELL EMITTER WAVESHAPES

SYNC INTERNAL MINUS

10 volts/cm
.5 ms/cm

TEST POINT

GT 26 or GT 32

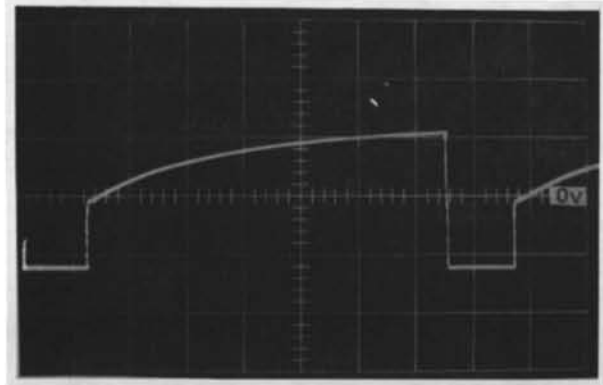

SYNC INTERNAL MINUS

10 volts/cm
.5 ms/cm

TEST POINT

GT 8 or GT 14

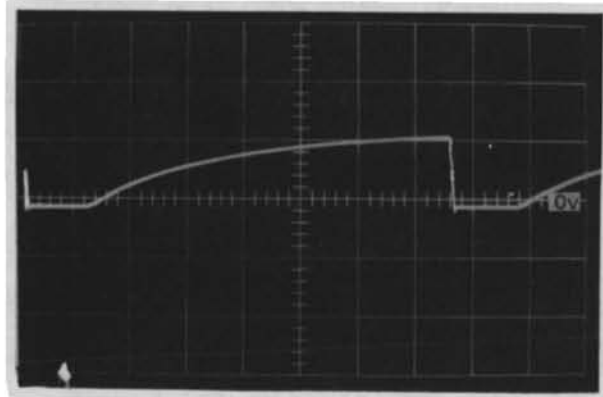

SYNC INTERNAL MINUS

10 volts/cm
.5 ms/cm

TEST POINT

GT 5 or GT 11

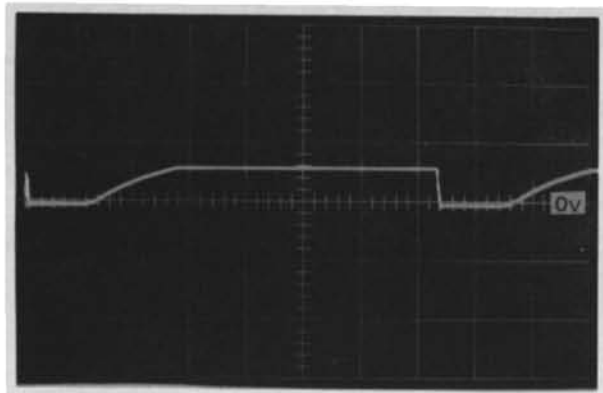

SYNC INTERNAL PLUS

10 volts/cm
.5 ms/cm

TEST POINT

GT 4 or GT 10

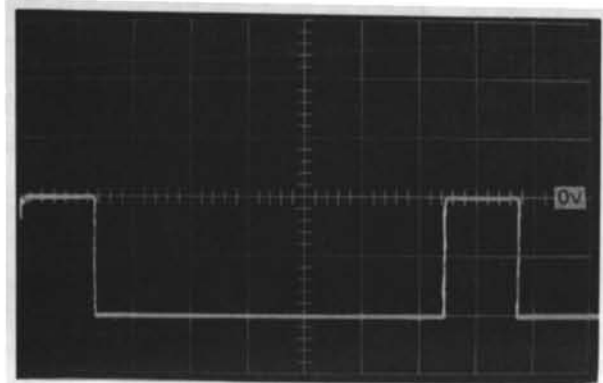

OUTPUT OF SOLAR CB CARD AT RELAY 7-5
FIRST PULSE READING 80 HOLES - SECOND
PULSE READING NO HOLES

SYNC SCAN SEVEN DISPLAYING SIX AND
FIVE TIME

UPPER TRACE VOLTAGE PATTERN

1 ms/cm
10 volt/cm

LOWER TRACE CURRENT PATTERN

1ms/cm
100 ma/cm

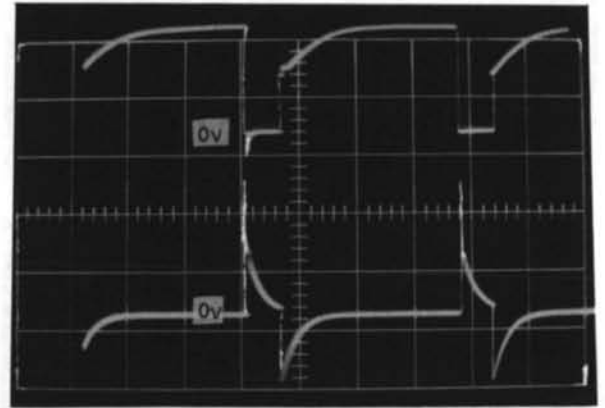

OUTPUT OF BRUSH IMPULSE CB's AT RL 7
FIRST PULSE READING 80 HOLES - SECOND
PULSE READING NO HOLES

SYNC SCAN 7 DISPLAYING SIX AND FIVE
TIME

UPPER TRACE VOLTAGE PATTERN

1 ms/cm
10 volt/cm

LOWER TRACE CURRENT PATTERN

1 ms/cm
1 amp/cm

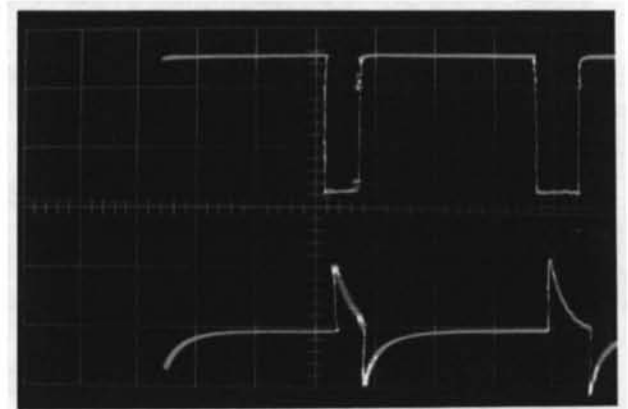

BRUSHES

USE THESE SCREWS TO
ADJUST BRUSH TRACKING

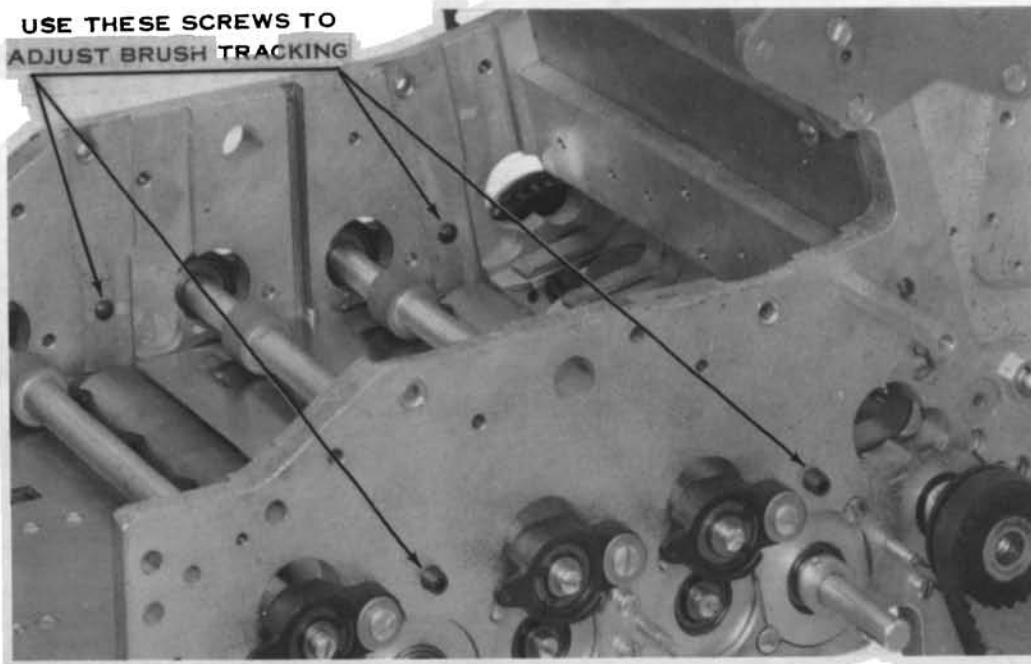

BRUSH ASSEMBLY ADJUSTMENTS

- 1 Check for .018" clearance between brush separator and contact roll. (Tolerance - .015" to .040". End to end variation - .015" maximum.)
- 2 The scribed line shows the best brush to contact roll relationship. There are four combinations of brushes and brush separators in use.
 - a Three group brushes, one scribed line. Set heel of shortest brush group on scribed line.
 - b Three group brushes, two scribed lines. Set heel of shortest brush group on scribed line nearest hopper.
 - c Two group brushes, one scribed line. Set heel of shortest brush group .050" beyond scribed line (toward stacker).
 - d Two group brushes, two scribed lines. Set heel of shortest brush group on scribed line nearest stacker.
- 3 Dynamically time brushes to wiring diagram by shifting picker knife timing.
 - a If picker knife cam is clamped to shaft, loosen cam to time brushes.
 - b If picker knife cam is pinned to shaft, loosen input pulley to time brushes. (If this is done, the RL CBs and solar CB must be retimed.)
- 4 Brush tracking adjustments.
 - a Center brushes in separator with two Allen-head set screws in brush assembly frame.
 - b Adjust screws in machine side frame for correct brush tracking.

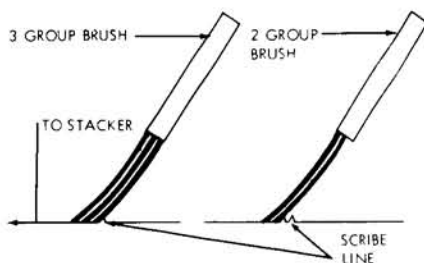

TIME BRUSHES WITH PICKER KNIVES.

TRACK BRUSHES WITH SCREWS IN SIDE FRAMES.

ONE EXCEPTION - Punch check brush timing is controlled by the second stepped feed roll.

BRUSHES ARE CRITICAL - USE EVERYTHING AVAILABLE TO CHECK THEM

DYNAMIC TIMER
SCOPE
VOLT-OHM METER

A strict PM procedure on brushes is essential for reliable machine operation.

Checking brush timing and tracking should be done as part of any feed PM.

SCOPING READ BRUSHES

1. Punch cards with the same digit in several columns.
2. Program a read and branch to itself.
3. Pull out the read brush wire to the brush you wish to scope. (This will allow -21 volts to feed from the other brushes to the contact roll and out the brush you are scoping.)
4. Sync the scope internally.
 - a. 10 volts per division
 - b. 1 ms per division

The relation of the impulse CB to the brush can be seen using this method. (When the impulse CB makes, 0 volts is put on the contact roll showing the impulse during the time the brush is made.)

The "Over-trace" shown in the illustrations on this page is caused by the brush making on the contact roll between cards.

Careful checking of brush timing will in many instances detect defective parts before they cause machine troubles. A stretched belt or worn keyway may give a highly intermittent trouble which can be very difficult to diagnose. Many such troubles can readily be determined by dynamically checking brushes.

When checking brush timing, note carefully the leading and trailing edge of the card. A variation may appear which cannot be seen at a particular digit time.

Use intermittent clutch motion to put maximum stress on belts, pulleys, feed rolls, clutch, etc.

A scope can be very useful to check brushes. If the brushes are not set to the scribed line, a bouncing condition will result. This cannot be seen with the dynamic timer. It is easily seen with a scope.

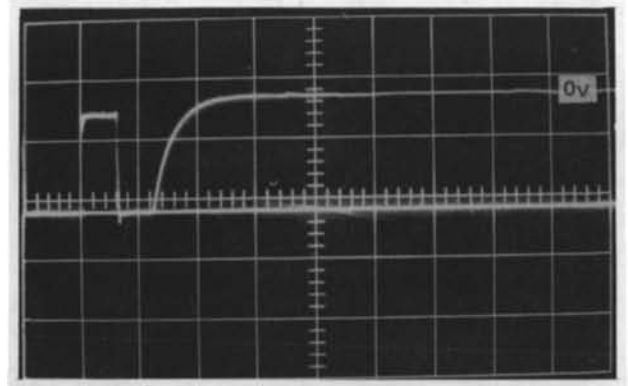

BRUSH TIMED CORRECTLY

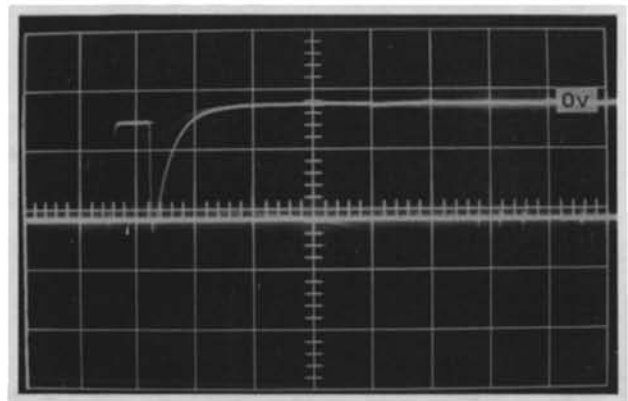

BRUSH MAKING EARLY

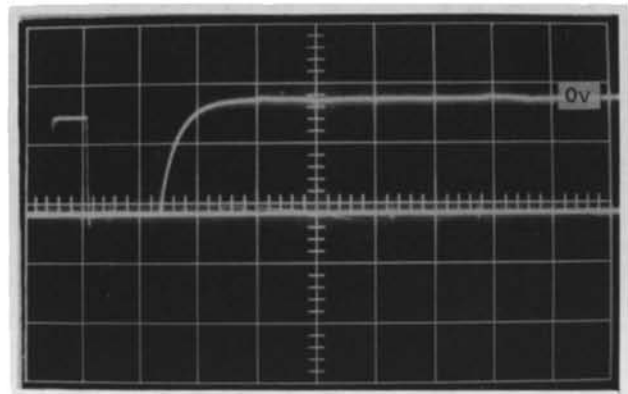

BRUSH MAKING LATE

A scope is also most helpful in getting the proper relationship of the brush and impulse CB. A current probe can also prove useful.

Adjust common brush for minimum resistance to reading brush with machine running.

BRUSH AND CB WAVESHAPES

SYNC SCAN SEVEN AND DISPLAYING SIX TIME. SCOPING 1 BRUSH

UPPER TRACE VOLTAGE PATTERN

1 ms/cm
10 volt/cm

LOWER TRACE CURRENT PATTERN

1 ms/cm
40 ma/cm

#1

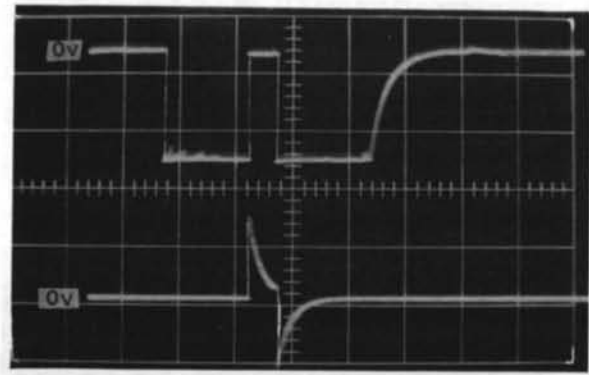

#2

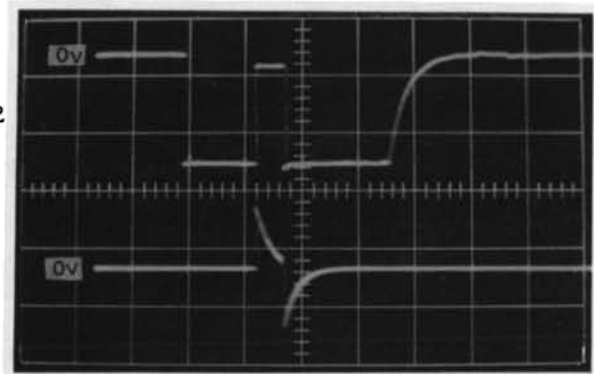

PICTURE #1

Reading 1 hole on machine with brass rolls and RLCB's

PICTURE #2

Reading 80 holes on machine with brass rolls and RLCB's

PICTURE #3

Reading 1 hole on machine with carbon rolls and solar emitter

PICTURE #4

Reading 80 holes on machine with carbon rolls and solar emitter

#3

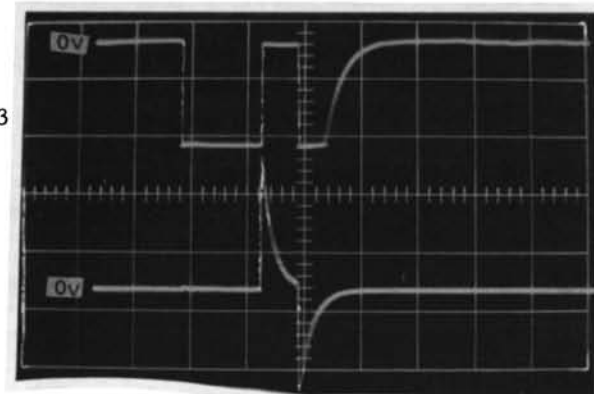

#4

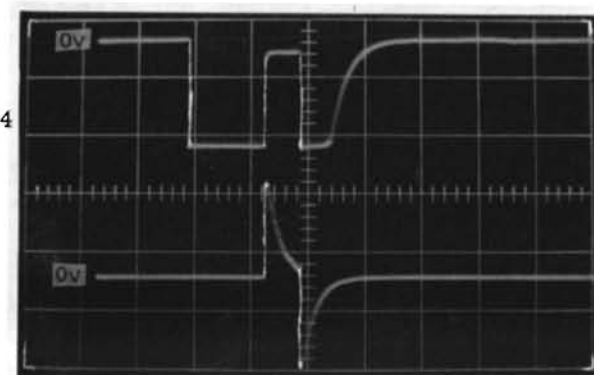

COMMON BRUSH ON MACHINE WITH CARBON ROLLS AND SOLAR EMITTER. FIRST PULSE READING 80 HOLES - SECOND PULSE READING NO HOLES

SYNC SCAN 7 DISPLAYING SIX AND FIVE TIME

UPPER TRACE VOLTAGE PATTERN

1 ms/cm
10 volt/cm

LOWER TRACE CURRENT PATTERN

1 ms/cm
2 amp/cm

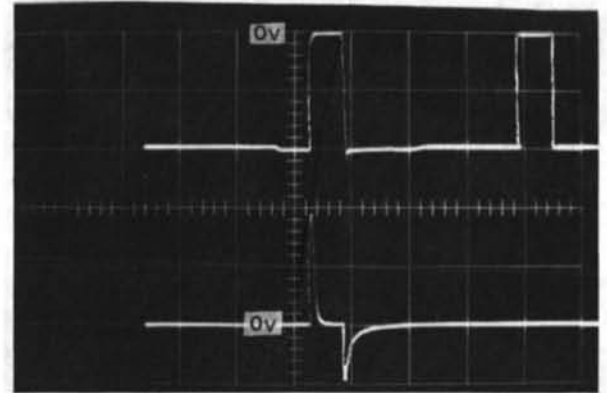

COMMON BRUSH ON MACHINE WITH BRASS ROLLS AND RLCB's. FIRST PULSE READING 80 HOLES - SECOND PULSE READING NO HOLES

SYNC SCAN 7 DISPLAYING SIX AND FIVE TIME

UPPER TRACE VOLTAGE PATTERN

1 ms/cm
10 volt/cm

LOWER TRACE CURRENT PATTERN

1 ms/cm
2 amp/cm

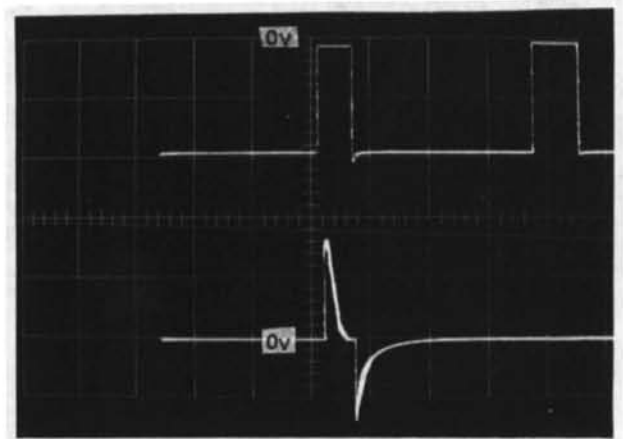

NOISE

ELECTRICAL NOISE

Noise can be described as any unwanted electrical disturbance to a circuit. Transistorized machines such as the 1401 can be adversely affected by a small amount of noise because of the low voltage levels of the signals used.

Noise generated in the 1402 usually comes from back EMF of collapsing coils and arcing or bouncing CBs, card lever points, and motors.

The following is a list of noise reduction B/Ms released for the 1402:

Minus 20 volt noise suppression
B/M 605300 1402 E/C CEM 9

Select magnet noise suppression
P/N 610295 1402 E/C CEM 18

Read clutch noise suppression
B/M 605263 1402 E/C CEM 20

Eliminate PL-11 contact bounce
B/M 605202 1402 E/C CEM 25

51-80 PFR noise elimination
B/M 605302 1402 E/C CEM 31

PFR static elimination
B/M 605368 1402 E/C CEM 36

Card lever noise suppression
B/M 605462 1402 E/C CEM 57

Suppress noise on input output lines
B/M 605296 1402 E/C CEM 62

Latch reset drive and PA 3-4 arc suppression
B/M 605305 1402 E/C CEM 66

1402 II noise elimination
B/M 605313 1402 E/C CEM 67

Improved PMT capacitor noise suppression
B/M 605487 1402 E/C CEM 85

PFR PL 17 noise suppression
P/N 609746 1402 E/C CEM 87

Eliminate sync checks and failure to space after print when 1402 stop key is depressed
B/M 605384 1402 E/C CEM 92

2-20 reader

Noise filter capacitor on main line circuit breaker
B/M 605496 or 605497 1402 E/C CEM 93

In addition, a significant reduction in the noise present on the minus 20 volt line may be achieved by adding a 47 ohm 1 watt resistor between the frame side of the 3 capacitors on the PMT common and the machine frame. (As a temporary trouble shooting aid, this point may be tied directly to the machine frame. This will determine if a machine problem is being caused by noise on the -20 volt line.)

Noise on the minus 20 volt line can trigger the solar CB amplifier card extraneously during a combined read-punch op.

Missing, misplugged, or defective suppressor devices can cause highly intermittent machine failures.

TO SUMMARIZE, SOME KNOWN SOURCES OF NOISE IN THE 1402 ARE:

- a CBs
- b Relay coils
- c Select magnets
- d Punch magnets
- e Card levers
- f Motor start contacts
- g Open or miswired suppression circuits
- h PACB latch reset not resetting punch magnet drivers before PA 5-8 breaks
- i If PFR has been mechanically installed but the contact roll is not yet wired, a static discharge may occur
- j A loose or high resistance frame ground at the AC input cable
- k Broken lead on capacitor 14 across PACB 8

Try to relate the noise to the type of operation being performed by scoping DC voltages at the 1402 CE panel and in the 1401.

NORMAL NOISE ON MINUS 20 VOLT LINE
WHILE PUNCHING ALL COLUMNS WITH
SIXES.

SYNC SCAN SIX

SWEEP @ 1 ms/cm
AC INPUT 5 volt/cm

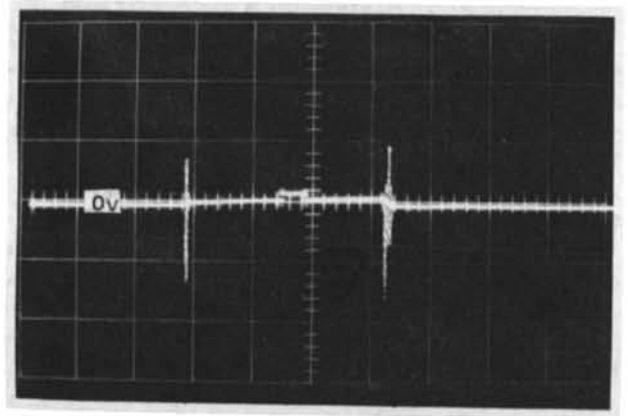

NOISE ON MINUS 20 VOLT LINE CAUSED BY
OPEN PUNCH MAGNET SUPPRESSION DIODE,
PUNCHING ALL COLUMNS WITH SIXES.

SYNC SCAN SIX

SWEEP @ 1 ms/cm
AC INPUT 5 volt/cm

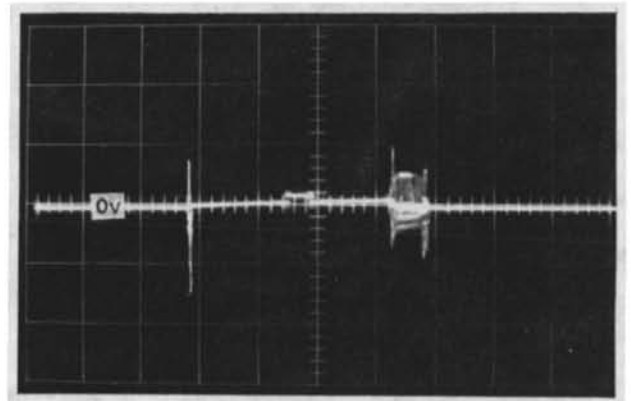

TRANSPORT

JAMMING IN STACKER

Check the card pusher and card support slides for binds. A cast aluminum stacker slide is available to replace black bakelite stacker slides (Ref: 1402 E/C CEM 12).

A stacker card stop P/N 603732 is available to prevent the cards from following the card pusher on its return stroke. This will eliminate the tendency of the cards to vertically climb out of the stacker due to excessive motion of the card deck.

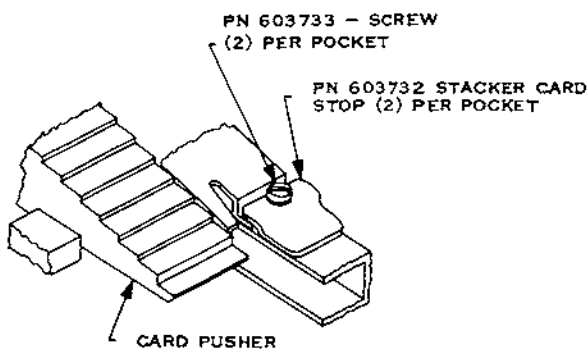

To gain more drive of warped and pliable cards, screw holes in the card pusher slide can be elongated to push cards about 1/16" further into stacker.

Check the radial card guides for nicks, burrs, and proper adjustment.

Make sure the card alignment lever holds 4 to 7 cards before allowing them to drop to the card pusher.

Jamming caused by excessive settling down time of the cards in the stacker may be minimized by applying strips of tape vertically along the top inside surface of the stacker side plates. The tape acts as a bumper for the card and dampens the shock of the card hitting the side plate.

Stacker card alignment levers and ledge restraining levers must be clean and free of binds.

The lower pressure rolls must be centered directly below the upper feed rolls.

The pressure rolls are adjusted so that a pull of 1.5 to 2.5 lbs is required to pull a strip of card through the rolls in the same direction that it would be fed. (Tension on front and rear rolls must be within 1/4 lbs of each other) A new style pressure roll is available (1402 E/C CEM 79).

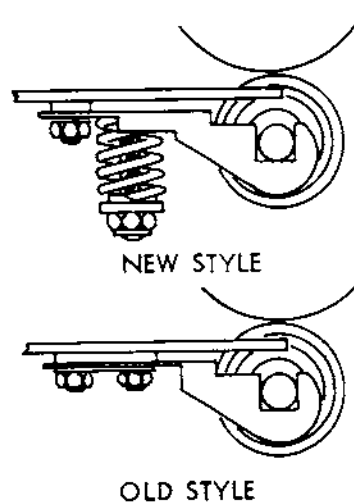

JAMMING IN TRANSPORT AREA

Round off the jam tape hanger to remove any possible burrs. This may be done by removing the shear plate to get at the hanger.

Make sure there is sufficient clearance (.015" to .035") between the jam tape hanger and the shear plate.

Check chute blade tension to insure that chute blade is stable. Flutter and bounce of chute blades will cause jamming.

Adjust chute blade positioning to the card line rather than to the shear plate, as a card feeding through the machine does not lie flat on the shear plate.

SELECTION FAILURES

A likely cause of wrong selection is the select magnet armature sticking to its core or its stop. Clean these areas with a card.

CARD RESTRAINING LEVER

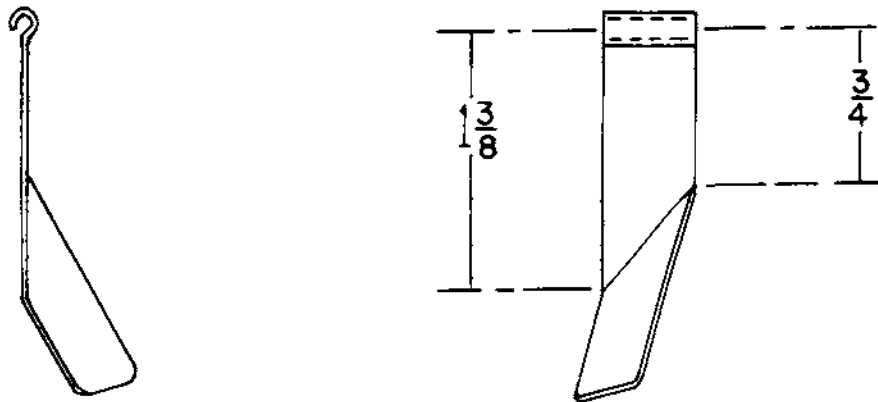

READ SIDE

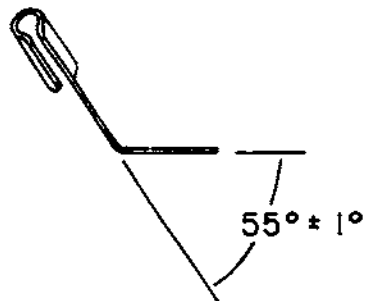

ADJUSTMENT PROFILE

ACTUAL SIZE

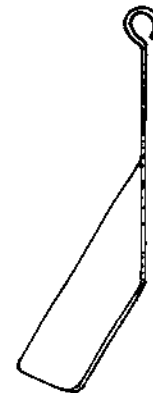
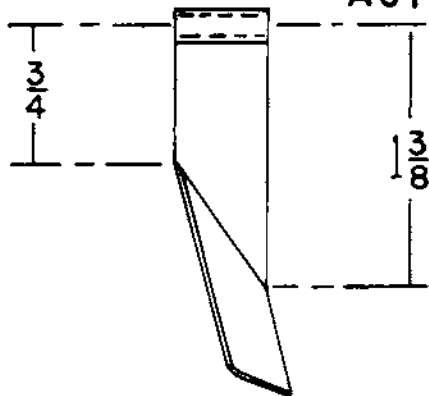

PUNCH SIDE

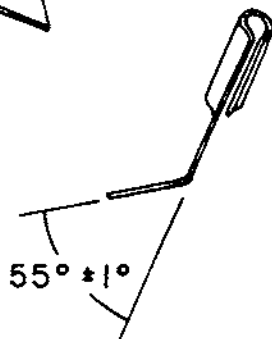

51-80

51-80 Column

This feature permits reading and stacking of 51-column cards into pockets NR and 1. The operator performs several operations to convert from 80 to 51 column operation. This feature applies only to the read feed.

To convert to a 51 column operation, perform the following steps:

- 1 Place the auxiliary hopper side plates in the hopper and secure solidly in place by means of the thumb screws.
- 2 Interchange 80 and 51 column card weights.
- 3 Insert auxiliary file aligners in upper part of file feed.
- 4 Program the read feed to stack in pockets NR and 1 only.
- 5 Pull the center portions of the radial guides in pockets NR and 1, into their forward detented position.
- 6 Pull the auxiliary ledges for pockets NR and 1 down and toward the rear of the machine to stop in the detented position.

When pocket NR is set up for a 51 column operation, a micro switch is operated. This switch connects -20V to the RC 191 connector and to logic 36. 16. 11. 2 then to 56. 80. 11. 2. This -20V sets the storage address register to 014 instead of 000 before each read scan. The other operation it performs is to bring up the last address line when the storage address register reaches 065 instead of 080.

With the 51-80 option installed, the chute blades are replaced with individual pocket selectors. Due to the positioning of the 8/2 pocket selector, a cycle of delay is required before energizing the magnet. When selecting to the 8/2 pocket in 80 column mode, relay SC-1 is used for this purpose. Relay SC-1 is picked from the 1401 and held through its own one point and CB RCSC-1 (330-240). At 150 of the next cycle, the select magnet is energized through relay SC 1-2 N/O and CB RCSC-2 (150-230). Selecting into the 1 pocket requires no special circuitry.

51-80 MECHANICAL ADJUSTMENTS

HOPPER

- 1 Adjust the hopper normally for 80 column cards.
- 2 Position the 51 column auxiliary hopper side plates so that brush 15 tracks column 1.
- 3 Adjust the auxiliary hopper side plates to provide .009 to .014 clearance over the length of the cards. (one card loose, two cards tight).
- 4 The side joggler should have .002 to .005 clearance at the top of the card deck.
- 5 The hopper card lever is positioned so that the contact makes when the tip of the lever is .060 to .090 above the surface of the picker knives.
- 6 To prevent card marking and card feed failures, all 4 joggler sensing pads on the front joggler gate should be even. This may be checked by placing a straight edge on the 4 sensing pads.
- 7 Throat jamming can be reduced by adjusting the center of the throat roller .002" past the throat knife.

POCKET SELECTION

- 1 Adjust the select magnet armature stop to provide .040 clearance between the armature and stop with the armature attracted.
- 2 Adjust the select magnet assembly up or down to obtain a minimum of .025 motion of the chute blade above and below the card line.
- 3 Bounce in chute blade can cause jamming and selection failures.

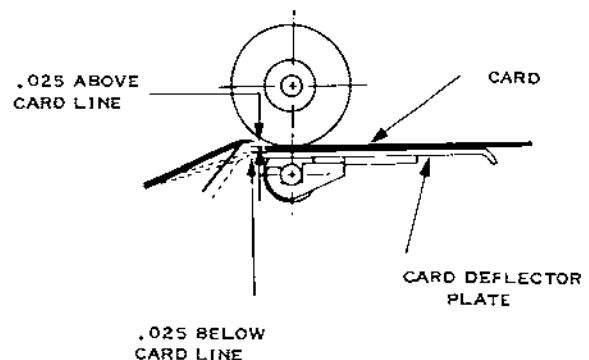

STACKERS

- 1 The ledge roller should be positioned with the two mounting screws so that the ledge is snug and parallel to the card path but still slides easily.
- 2 The radial card guide deck arrestor is adjusted to obtain $3/16$ " above the radial guide.

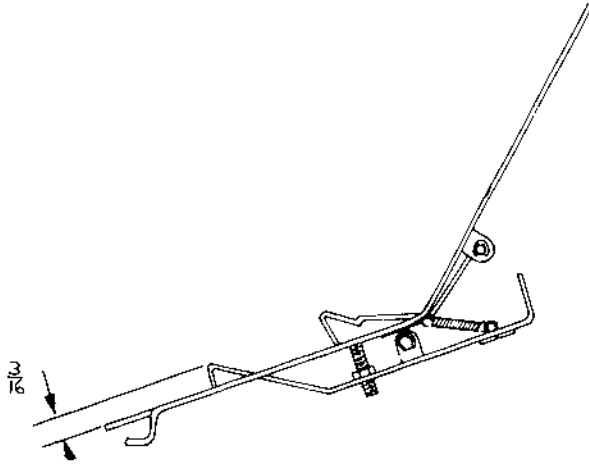

- 3 The 51-80 card retainer extenders should be adjusted .1" beyond the front upper ledge. Add or remove shims.

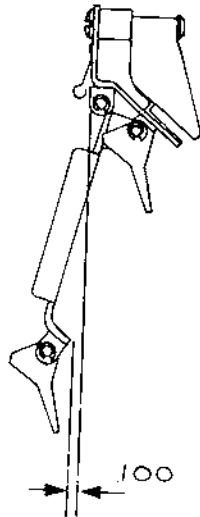

- 4 The open end of the "C" clip on the ledge card restraining lever should face in the direction of card travel.

51-80 RADIAL CARD GUIDE ADJUSTMENT PROFILE

MALFORMED RADIAL CARD GUIDES CAN BE A CAUSE OF EXCESSIVE CARD JAMMING. TO ELIMINATE THIS AS A CAUSE, FORM THESE GUIDES TO MATCH THE ILLUSTRATED PROFILE. DO NOT DISTORT THIS PROFILE TO ACCOMPLISH REINSTALLATION. IF MOUNTING SCREW HOLES DO NOT ALIGN, ELONGATE THE UPPER MOUNTING SCREW HOLE TO THE REQUIRED EXTENT BY FILING.

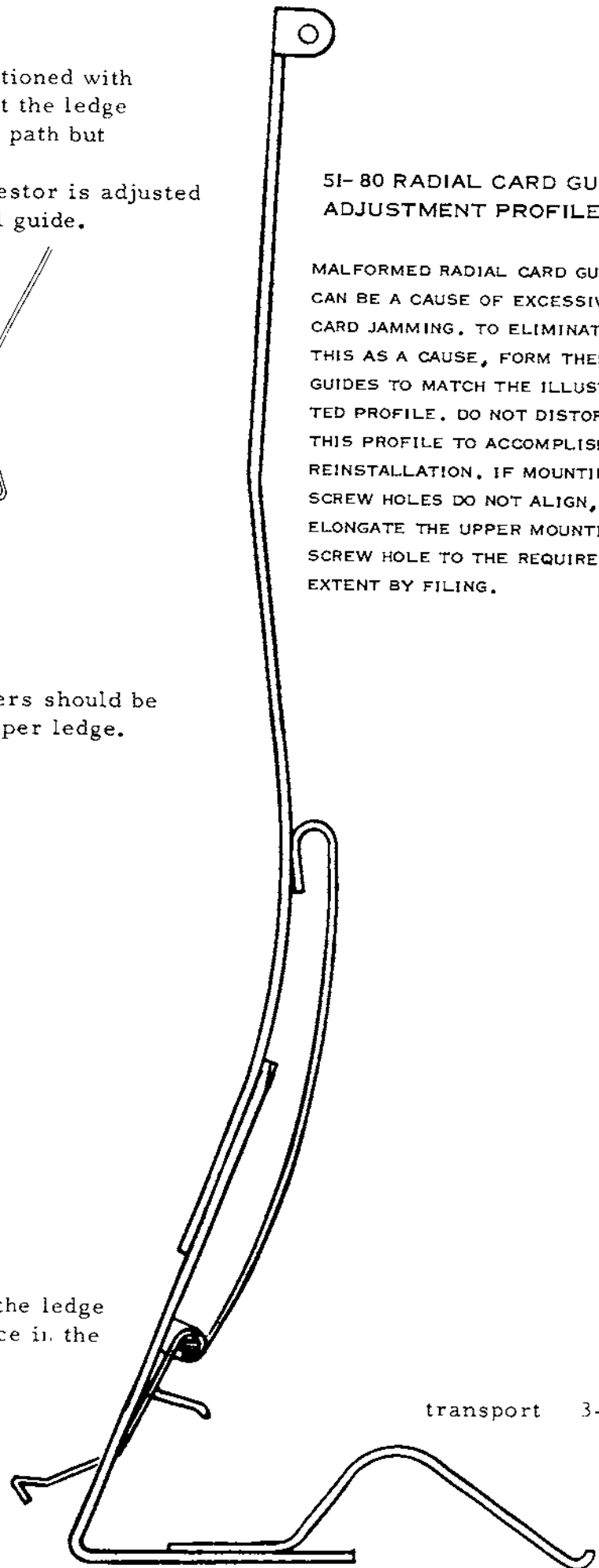



PUNCH STOP

PUNCH STOP LIGHTS

CARD FEEDING FAILURES

- 1 Make certain that all hopper adjustments are correct. Feeding failures or attempting to feed two cards may be caused by backward travel of the feed knives in excess of .030 behind the card. Feed knife travel should be .015 to .025 behind the card.
- 2 Make certain that the customer is not using an 083 sorter card weight. It is not cut out for the hopper card lever.
- 3 Too much tension on the hopper card lever may lift the cards from the feed knives.

CARD LEVER FAILURES

- 1 Card lever timing is critical and should be checked with the timer. Check card levers for bounce, loose points, insufficient rise, and pitting.
- 2 The die card lever adjustment is difficult because it has a very small amount of over-all travel.

PUNCH CLUTCH FAILURES

Clutch failures fall into two categories, failure to latch and failure to unlatch. Failure to unlatch is the most likely. A failure to unlatch can be very deceptive because the clutch will usually unlatch for the next tooth on the ratchet. Due to the design of the 1401 circuits, the clutch magnet will remain energized, the makes it appear as if the clutch failed to latch due to a solid shot to the magnet. If this condition exists, check the unlatching clearance adjustment in the reference manual. Also, check timing and condition of PL6.

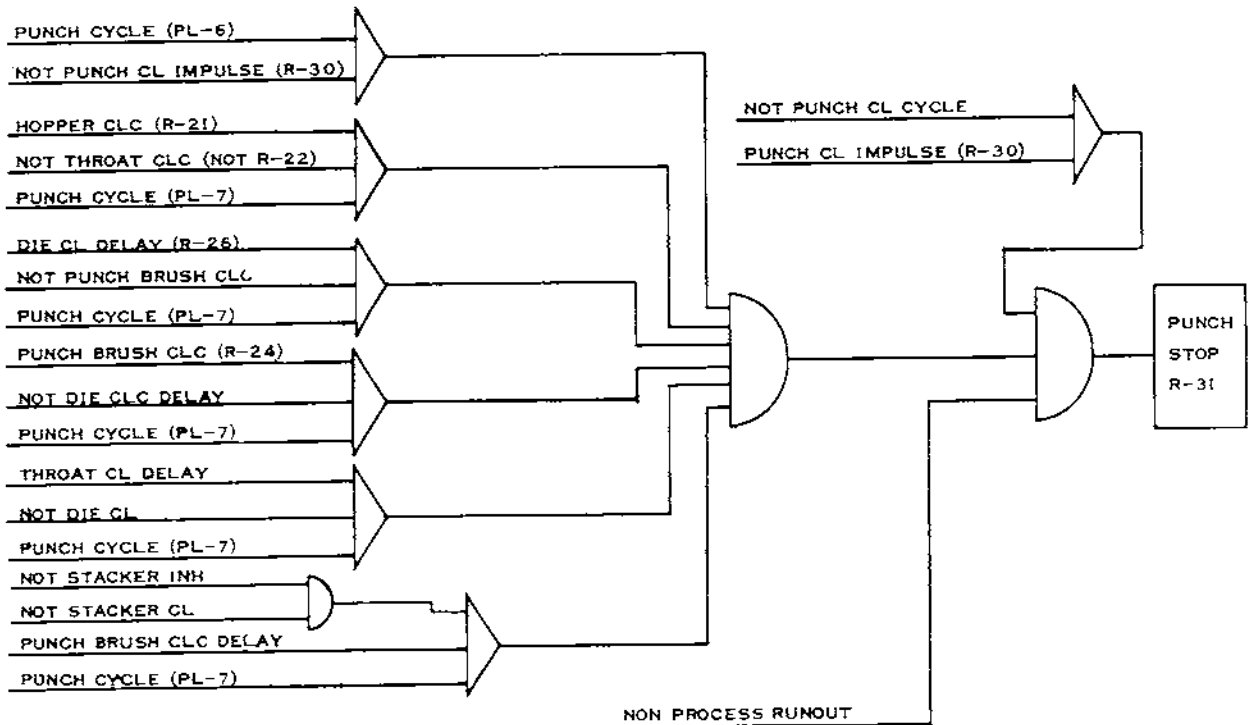

OFF PUNCHING - JAMS

SEQUENCE OF ADJUSTMENTS

PUNCH FEED

- 1 FIRST STEPPED FEED ROLL
- 2 FIRST INTERMITTENT ROLL
- 3 SECOND STEPPED FEED ROLL
- 4 SECOND INTERMITTENT ROLL
- 5 FORWARD AND SIDE ALIGNERS

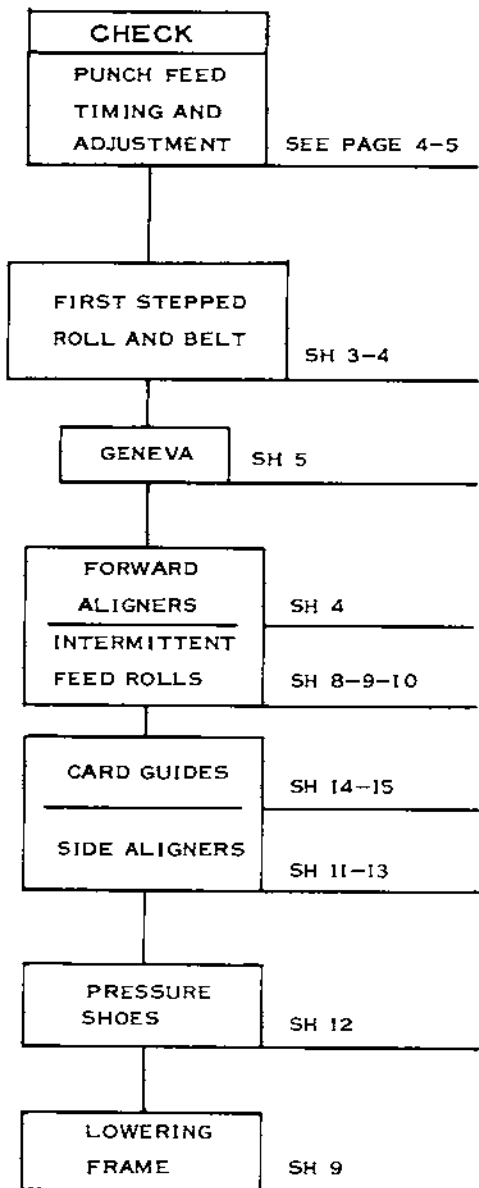

ON INTERMITTENT JAMMING PROBLEMS REMOVE THE PUNCH UNIT AND FEED CARDS UNDER POWER. TRY TO DUPLICATE THE FAILURE.

VARY THE AMOUNT OF CARDS IN THE HOPPER.

FORCE THE CARDS TOWARD THE SIDE PLATES.

USE THE SAME TYPE OF CARDS THAT CAUSED TROUBLE FOR THE CUSTOMER.

TO FEED CARDS THROUGH THE PUNCH FEED TURN OFF THE PUNCH SWITCH AND RUN CARDS WITH THE NON-PROCESS RUN OUT KEY.

PUNCH FEED SERVICE HINTS

- 1 A common cause of off punching or jamming is improper adjustment and timing of the punch feed.
- 2 **CRITICAL TIMING**
The first intermittent feed roll must have complete and definite control of the card at 357°. At 0° time, the geneva imparts motion to the intermittent rolls.

A very careful check of the closing time of the first intermittent feed rolls will eliminate many off-punching problems.
- 3 A common cause of intermittent off punching is the first stepped feed roll drive belt. On PFR machines this can be detected by close observance of the PFR brush timing. On non PFR machines there is no such aid. If the off punching is consistently high, the trouble is most likely to be stepped feed roll drive belt (ref: 1402 E/C CEM 40).
- 4 Check that the trailing edge of the card travels at least 1/32" past the forward aligners. If this condition does not exist, carefully check the timing of the first stepped feed roll. If timings are correct, it may be necessary to change the picker knife cam timing slightly to insure that the card travels 1/32" past the forward aligners.
- 5 Varying vertical registration may be caused by the geneva--

--grip an intermittent roll and attempt to turn in both directions checking for slight wink at all 12 digit times.
- 6 A likely cause of punch feed failures is a defective component. Before changing adjustments, determine that feed components are in good condition.
- 7 If the vertical registration is off more than a few thousandths of an inch, the punch unit adjustment is not likely to be the cause. Investigate some other possible source of trouble.
 - a Incorrect operation and timing of aligner station.
 - b Improper card feeding--loose feed roll belts, card guides, pressure shoes, etc.
 - c Worn or loose geneva studs and gears.

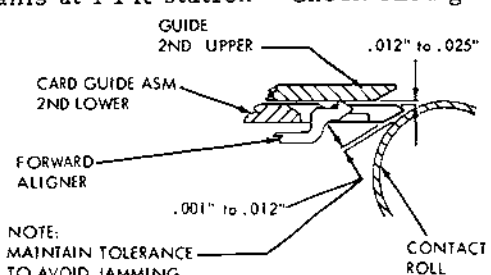
- 8 Varying registration can be caused by insufficient intermittent roll tension, cam follower bottoming, or a weak spring. Check for binds and check the cam follower bearing for wear and looseness.
- 9 Before changing eccentric adjustments of intermittent feed rolls, be sure that lowering frame assembly is operating properly. A loose key in handle may prevent the lowering frame from closing completely.
- 10 Intermittent feed roll eccentrics - Problem maintaining these adjustments may be caused by a frozen card feed roller on the lower shaft causing the shaft to rotate. The lower feed bearings must be free on the shaft.
- 11 **HOPPER SIDE PLATES ARE ADJUSTED TO THE STATIONARY SIDE ALIGNER, NOT FOR BRUSH TRACKING.**
- 12 If vertical registration varies slightly, check the pressure shoe springs for tension. Make certain pressure shoes are not binding.
- 13 Card punched low on one end. Check side aligners for timing, adjustment, binding, and wear.
- 14 Card guides must be kept in proper relationship to card line and adjusted for correct clearance.
- 15 Jams at PFR station - Check card guide.

The diagram shows a cross-section of a card guide assembly. It includes labels for 'GUIDE 2ND UPPER', 'CARD GUIDE ASM 2ND LOWER', 'FORWARD ALIGNER', and 'CONTACT ROLL'. A dimension line indicates a clearance of '.012" to .025"' between the upper and lower guides. Another dimension line indicates a clearance of '.001" to .012"' between the forward aligner and the contact roll. A note states: 'NOTE: MAINTAIN TOLERANCE TO AVOID JAMMING'.
- 16 Punch Drive Unit Position - Off-punching, poor card feeding, and incorrect tension of the PA CB drive belt can be the result of a tilted punch drive unit. Whenever it becomes necessary to adjust the vertical position of the punch unit, it must be checked for squareness. (Ref: 1402 S/A CEM 2)
- 17 Varying registration may be caused by intermittent rolls becoming polished.

PUNCH TRANSPORT ADJ.

First Stepped Feed Roll

- 1 Trip clutch at 300° and manually crank machine to 330°. Loosen split hub of pulley on front of first stepped feed roll.
- 2 With machine at 330°, turn first stepped feed roll by hand and insert a card lengthwise through the first stepped feed roll. Make sure card is not passing through intermittent rolls.
- 3 At the point at which first stepped feed roll stops feeding card, rotate roll slightly until card has light drag. Hold roll at this position and tighten pulley loosened in step #2.
- 4 Check that card is held tightly by first stepped roll at 328° and is free at 331°. (CHECK TIMING OF FIRST INTERMITTENT ROLL AND SECOND STEPPED FEED ROLL)

First Intermittent Feed Roll

- 1 Trip clutch at 300° and crank machine to 352°.
- 2 Insert a strip of card between each set of rolls of first intermittent feed roll.
- 3 Crank machine to 356°. Adjust eccentrics so each card has light drag.
- 4 Check to see that each card is free at 353° and gripped tightly at 357°.
- 5 With cards still in place, check that feed roll opening cam follower rollers are free from cam surface at 360°.

Second Stepped Feed Roll

- 1 Trip clutch at 300° and crank machine to 294°. Loosen split hub of pulley located on rear end of second stepped feed roll.
- 2 With machine at 294°, turn second stepped feed roll by hand and insert card lengthwise through second stepped feed roll. Make sure card is not passing through intermittent rolls.
- 3 At point at which second stepped feed roll BEGINS feeding card, rotate roll slightly until card has light drag. Tighten pulley loosened in step #3.
- 4 Check that card is held tightly by second stepped feed roll at 295° and is free at 292°. (CHECK SECOND INTERMITTENT FEED ROLL)

Second Intermittent Feed Roll

- 1 Trip clutch at 300° and crank machine to 290°.
- 2 Insert a strip of card between each set of rolls of second intermittent feed roll.
- 3 Crank machine to 286°.
- 4 Adjust eccentrics so each card has light drag at 286°.
- 5 Check that each card is free at 288° and gripped tightly at 284°.

Forward Aligners

- 1 Forward aligners must be parallel. Position mounting block to obtain this condition.
- 2 Place cards in hopper. Block clutch at 300° and continue cranking machine one complete cycle to 351°. Adjust forward aligners so trailing edge of card is against each aligning surface and leading edge of card is within .005" of forward aligner timing marks on timing gauge.

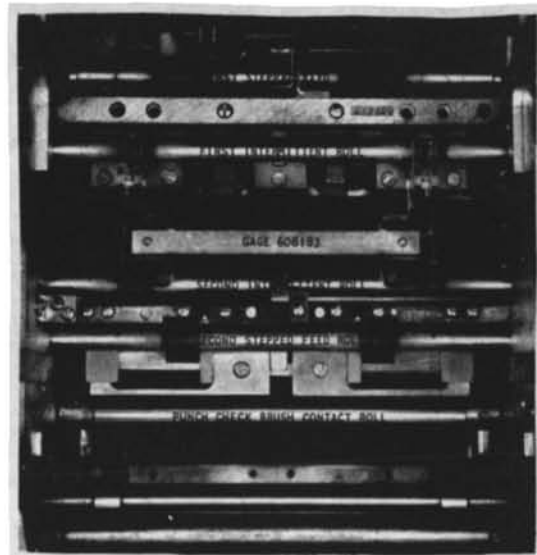

SUMMARY OF CHECKS OF PUNCH TRANSPORT

- 1 First stepped roll - Check that card is tight at 328°, loose at 331°.
- 2 Card aligned by 351°.
- 3 First intermittent roll - Check that card is free at 353°, tight at 357°.
- 4 Second stepped roll - Check that card is loose at 292°, tight at 295°.
- 5 Second intermittent roll - Check that card is tight at 284°, loose at 288°.

PUNCH TRANSPORT TIMING

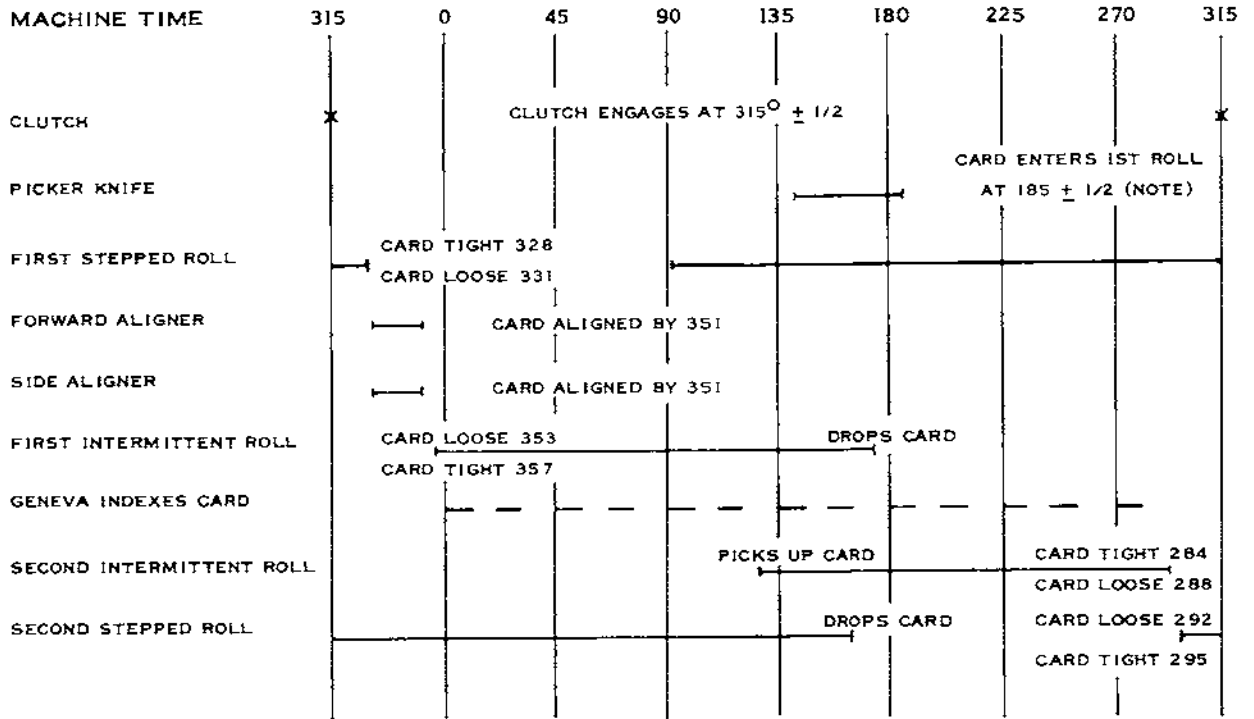

CRITICAL MACHINE TIMINGS SHOWN

NOTE - IT MAY BE NECESSARY TO CHANGE THE PICKER KNIFE TIMING SLIGHTLY TO INSURE THAT THE CARD TRAVELS 1/32 PAST THE FORWARD ALIGNERS.

FIRST STEPPED & FIRST INTERMITTENT FEED ROLL TIMING IS CRITICAL TO CORRECT PUNCHING REGISTRATION.

SECOND STEPPED FEED ROLL TIMING IS CRITICAL TO CORRECT PUNCH CHECK BRUSH TIMING.

PUNCH CHECKS

IF OVERLAP IS ON MACHINE
SEE SERVICE HINTS 20 & 21

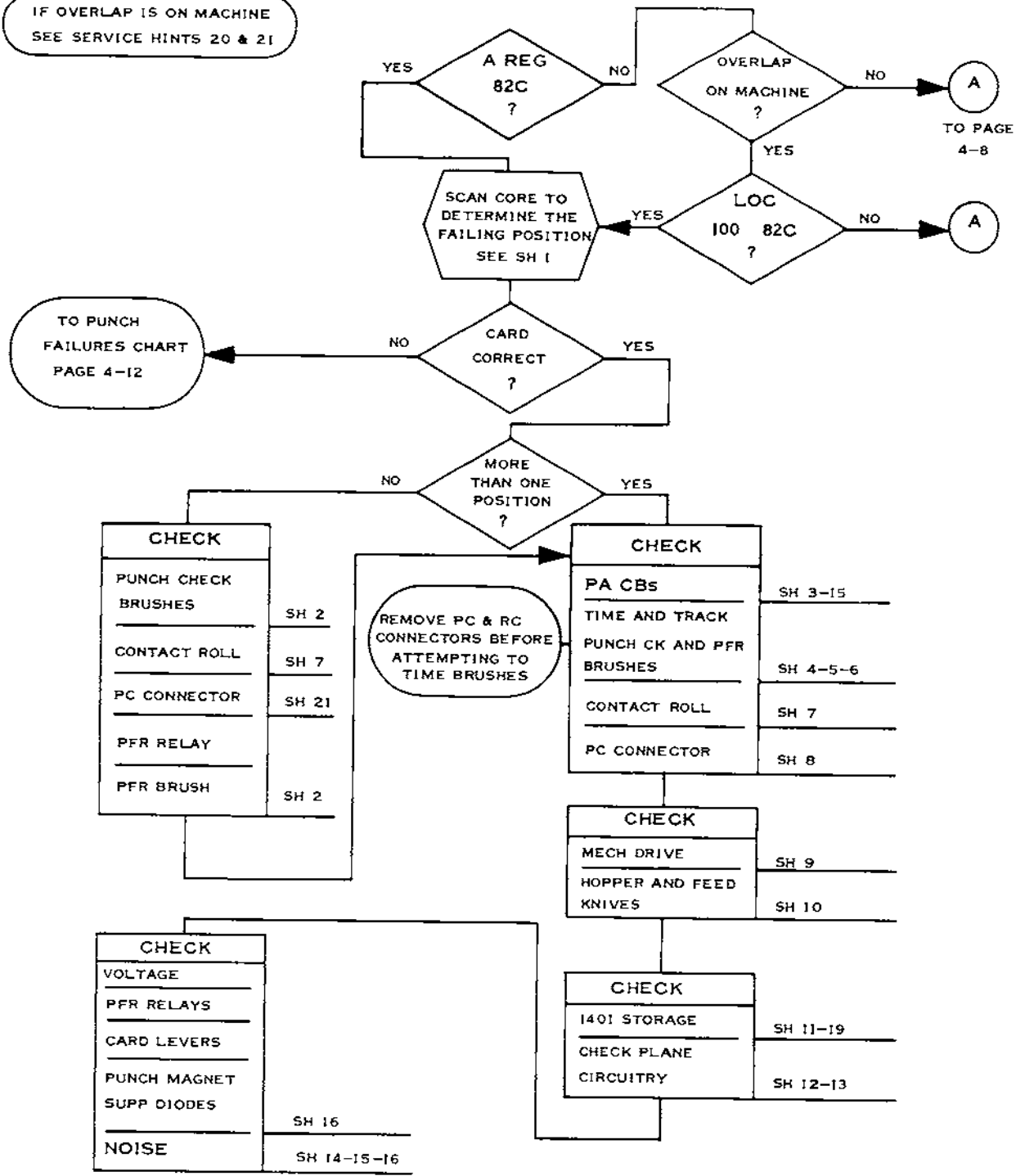

PUNCH CHECKS
(PART 1 OF 2)

SERVICE HINTS

- 1 To locate the column causing a punch check on a PFR operation, start scanning in core location 0100. Locations 1 thru 80 have check cores set.
- 2 For single position punch check failures, do not hesitate to replace both PFR and punch check brush in the failing position.
- 3 A LIKELY CAUSE OF PUNCH CHECKS IS THE PA CBs. (Refer to PA CB Section page 4-10)

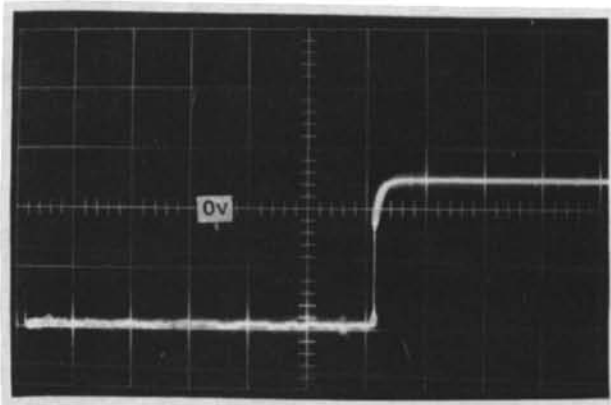

PACB's 1 & 2 SHOWING NO BOUNCE ON MAKE OR BREAK

SYNC MINUS INTERNAL

1 ms/cm
10 volt/cm

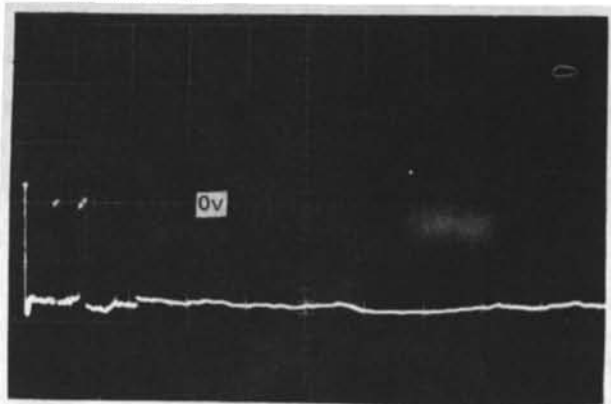

PACB's 1 & 2 BLOWN UP TO SHOW BOUNCE ON MAKE

SYNC MINUS INTERNAL

200 us/cm
10 volt/cm

- 4 TIME AND TRACK PFR AND PUNCH CHECK BRUSHES. PUNCH CHECK BRUSH CARD TIMING IS CONTROLLED BY THE 2ND STEPPED FEED ROLL. CHECK DRIVE BELT AND TIMING OF 2ND STEPPED FEED ROLL.
- 5 DO NOT TRACK PFR BRUSHES WITH HOPPER SIDE PLATES.
- 6 To check for short brushes or brush block skew, check brush timing with the PC & RC connectors in place. This effectively places all the brushes in parallel and allows them to be simultaneously displayed on the timer.
- 7 Make certain that the contact rolls are clean and that the drive gear set screws are tight.
- 8 To test the circuit from a brush through its associated row bit winding, remove the brush block and check for -21 volts on the brush (punch check brushes only).
- 9 Make certain that there are no stretched or worn belts and that all pulleys and gears are tight.
- 10 Too much tension on the punch hopper card lever can raise the card and cause a poor feeding condition.
- 11 A 1401 memory failure may appear as a punch check. Switch the sense amps for the RD 2 - Punch - and check planes to a bit line to determine if the failure is in this area. The current source and driver cards are also a possibility and should be eliminated by substitution. Any memory failure may show up as a single or multiple position failure.
- 12 If you storage scan after a false read or punch check and the 1401 does not stop on any error position, suspect check plane trouble. If the 1401 fails to write into or read out of the check planes, you will get false read checks when reading 12's and false punch checks when punching 9's.

PUNCH CHECKS

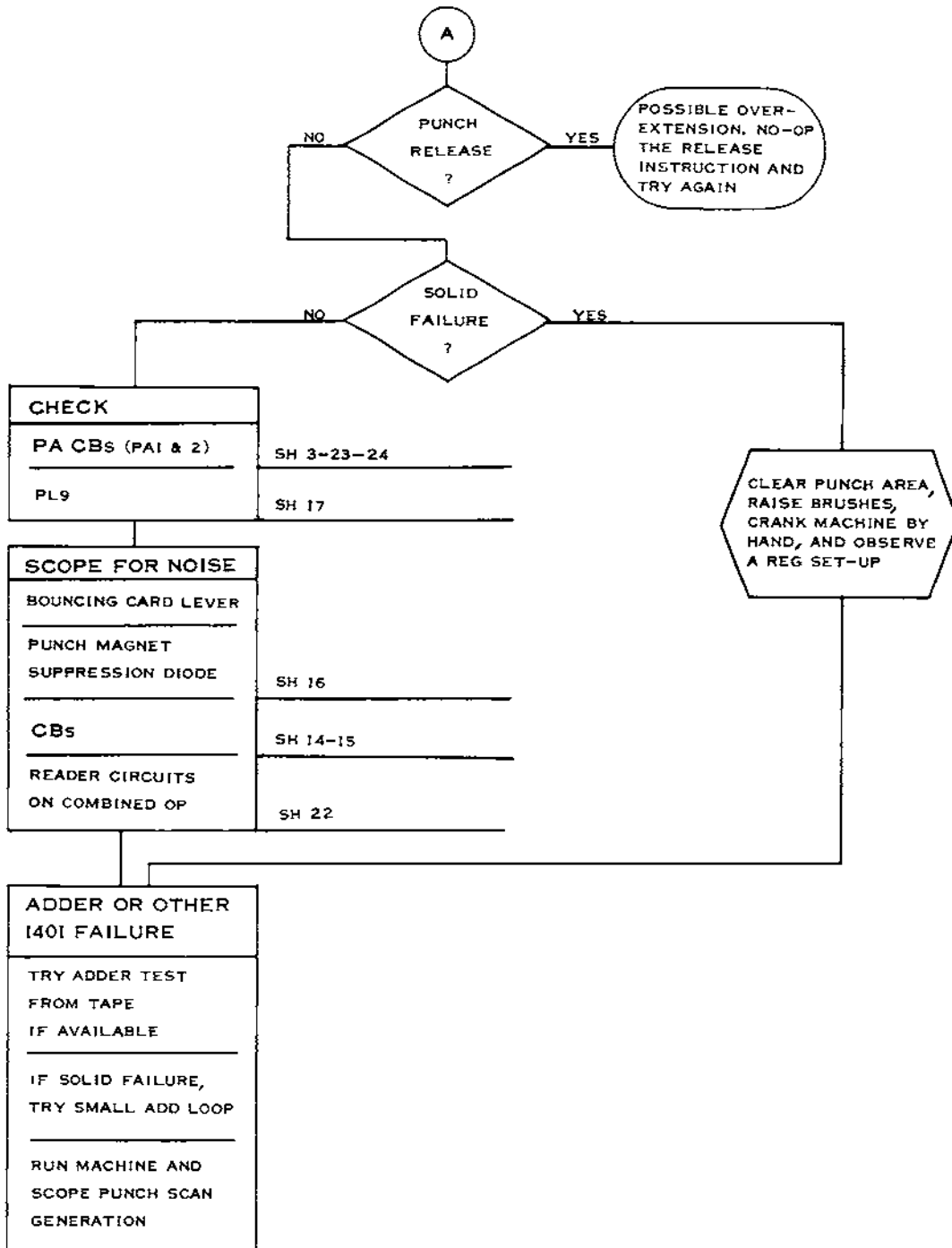

PUNCH CHECKS
(PART 2 OF 2)

- 13 If the failure appears to be on every other card, the check plane circuitry should be investigated.
- 14 1402s with PFR feature may experience intermittent punch checks because of noise generated by PL17. A .47 MFD capacitor will correct this condition (ref: 1402 E/C CEM 87).
- 15 Broken leads on C14 around PA CB 8 will cause punch checks (normally missing or extra scans).
- 16 Check the -20 volt line for noise caused by an open punch magnet suppression diode.
- 17 Missing scans can be caused by PL CB 9 failing to make.
- 18 A failure of the after zero trigger will usually cause the A reg to set all zones on all digits.
- 19 Wherever possible 1401 adder or logic failures should be approached from the 1401. When it is necessary to shoot them using a punch operation, a sync for any scan can be built from the output of the A reg combined bits on logics 35, 16, 51 thru 35, 16, 81. A sync for scans 2 thru 7 can be taken from the sense switches on logic 34, 22, 11.
- 20 To prevent O to A transfer on overlap machine and to keep scan count in A reg, turn tape select switch to any number.
- 21 Turn rotary switch on 1401 lower console to R/P off position to eliminate overlap mode.
- 22 Punch checks can be caused by noise generated by the reader. Refer to page 2-20.
- 23 Punch checks on run in only may be caused by defective JMVB card at 01B7A26 (failure to clear check planes on run in).
- 24 Punch checks can be caused by starting a scan while brush impulse is still present. Sync on fall of brush impulse and probe punch scans. This will include the after 9 scan.

PACB'S

SYMPTOM

CHECK

- | | |
|--|---|
| 1 Extra or missing punch scans | PA 1, 2, 3, 4, 11, 12, or 5 thru 8 |
| 2 Dropping punches - flag punching | PA 5 thru 8 |
| 3 Lacing columns or underpunching | PA 3, 4, 11, and 12 |
| 4 Drop punches in first few columns | PA 3, 4, 11, and 12 to 1 and 2* |
| 5 Erratic punching or half punching 9 edge of card | PA 1 and 2 |
| 6 Intermittent punch checks | PA 9 and 10 |
| 7 Changing characters in punch area | PA 1 and 2 |
| 8 Any random errors following or seemingly associated with a punch operation | PA 3, 4, 11, and 12 to PA 5, 6, 7, and 8* |

*Indicates timing relation of impulses

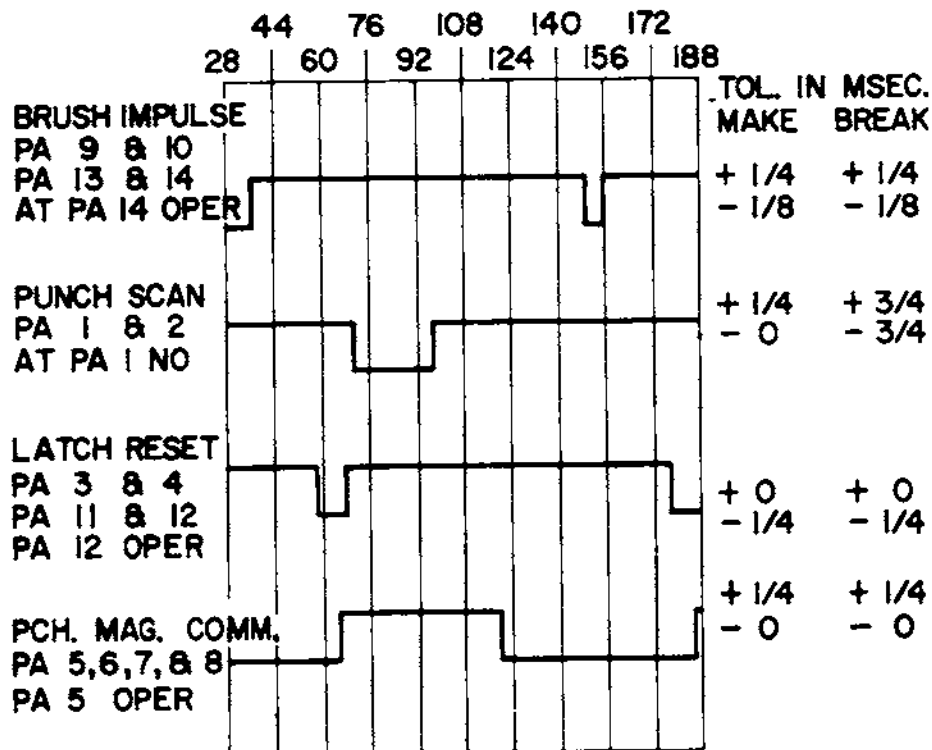

SCOPE PROCEDURE

- 1 Manually program a punch and branch instruction. Enter 12 through 9 in location 101 to 112.
- 2 Time PA 9, 10, 13, and 14 with an ohm meter to insure make time and duration is correct.
- 3 Sync scope on -T brush impulse at output of integrator in 1401 (logic 36.21.11.2).
- 4 Set time base of scope for 2 Msec per division. Each division of the scope will then be 16 degrees of the PA CB unit.
- 5 Display scope sync. Pulses should occur exactly 15 Msec apart. This is a check of the speed of the PA CB unit and must be correct for this procedure to be accurate. Adjust as closely as possible with the split pulley on the punch drive motor.
- 6 Scope punch scan CB, latch reset CB, and compare to diagram for timing and relation to each other.
- 7 Scope PA 5, 6, 7, and 8 at PA 5 O/P.
- 8 Change time base and scope sync as desired to more closely check for bounce and duration of individual CBs.

USE OF THIS PROCEDURE AS A PM OR TROUBLE SHOOTING TECHNIQUE IS HIGHLY RECOMMENDED.

SERVICE HINTS

- 1 The PA CBs should be clean and the tension adjusted to approximately 200 grams to eliminate bounce. Tension should be adjusted by disassembling the contact and forming the operating strap at the bend. Always scope the make and the break of the CB after adjusting to make certain that all bounce has been eliminated.
- 2 There are 3 types of CBs currently used which closely resemble each other. These are:

P/N 610073	Silver CB
P/N 435701	Tungsten CB
P/N 228110	024 Tungsten CB

The 024 tungsten CB MUST NOT be used in the 1402. The silver CB must only be used in those positions that are recommended as they will burn excessively if used in other circuits.

- 3 Silver point CBs have been released for use in PA CB positions 1, 2, 3, 4, 11, and 12. The recommended contact tension is 160 grams. Tension in excess of this will hammer out the soft silver material (ref: 1402 E/C CEM 77).
- 4 If punch checks and missing scans are being experienced after replacing and timing PA 1 and 2, check the PA CB plastic dust cover for adequate clearance to PA CB 1.
- 5 Check PA CB unit for correct timing to the punch unit index. Check CB drive belt for wear and sufficient tension.

PUNCH FAILURES

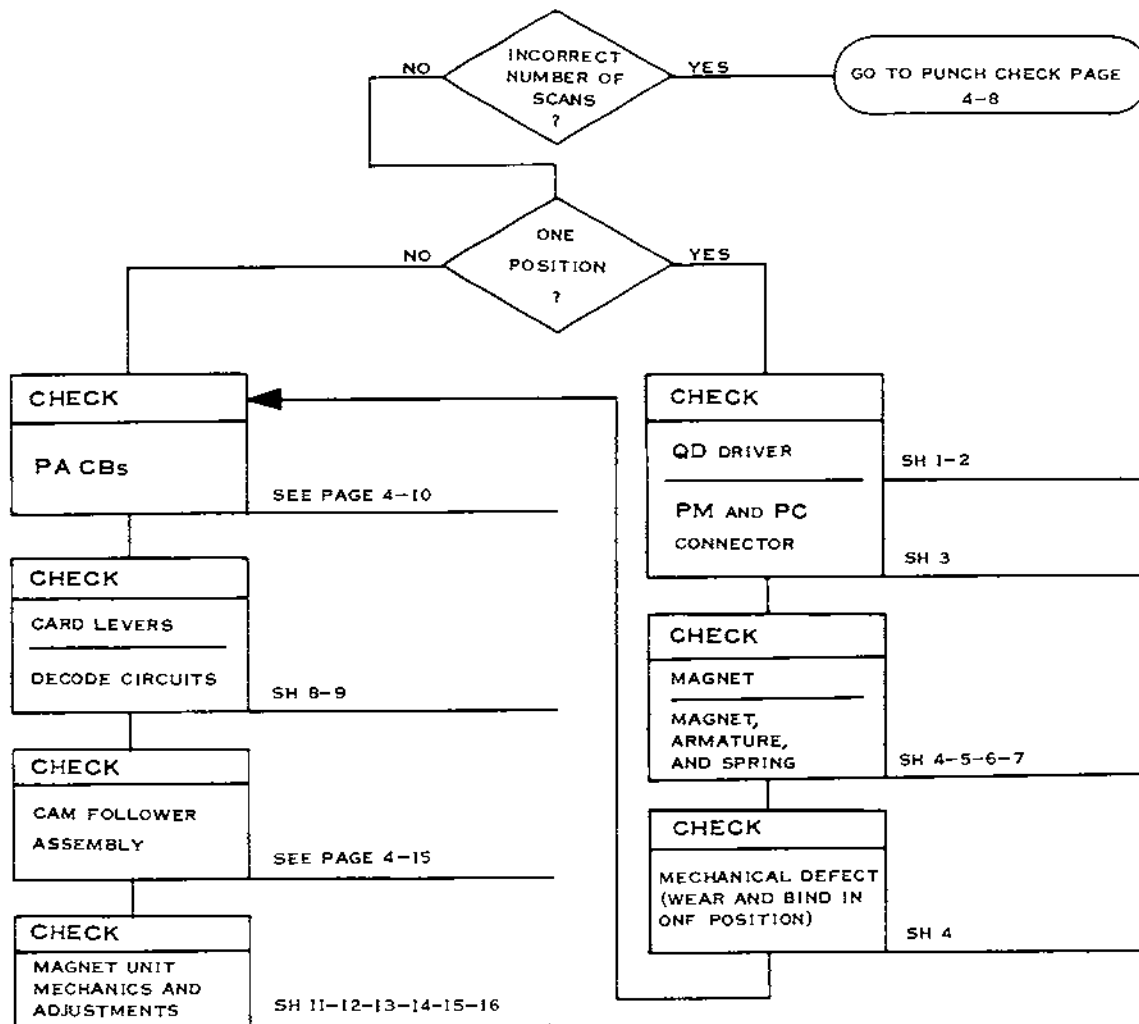

1 Swap QD driver in 1401.

2 Partial punching of holes can be caused by weak QD drivers. This condition is also caused by incorrect adjustment of PA 3 thru 8.

3 Swap punch connectors in 1402 (this swaps a complete horizontal row of magnets).

A	80 76 72 68 64	24 20 16 12 8 4	
CABLE			
B	79 75 71 67 63	23 19 15 11 7 3	
	78 74 70 66 62	22 18 14 10 6 2	C
			CABLE
	77 73 69 65 61	21 17 13 9 5 1	D

4 Check for bent or broken magnet armature spring, worn or binding armature, or anything that would prevent the armature from sealing to its core.

5 Binds in the armature may be caused by insufficient (.001 - .008) clearance between the armature and pivot rod. Check also that the magnet wires do not interfere with the armature travel.

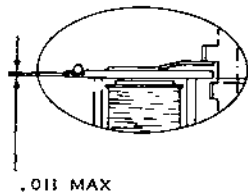

6 Excess grease or contamination may cause either a failure to seal or sticking of the armature.

7 Make certain there is .002 - .004 clearance between the armature and its core.

8 Continuous punching of extra cards with same information can be caused by after 9 cam failing to make or a card lever failure. A pulse on the punch jam line may be of sufficient amplitude or duration to turn on the punch stop trigger but too small to pick R31 (ref: 1402 E/C CEM 41).

9 The punch decode circuitry may be scoped at 1401 speed by using a Load or Move op with equal A and B fields (M180180). The equal compare between bits in the A and B registers will activate the Punch decode circuits.

The address decode circuits can be checked on Non-print buffer machines by performing the Ripple Print test. If printing is correct, the Address decode circuitry is not at fault.

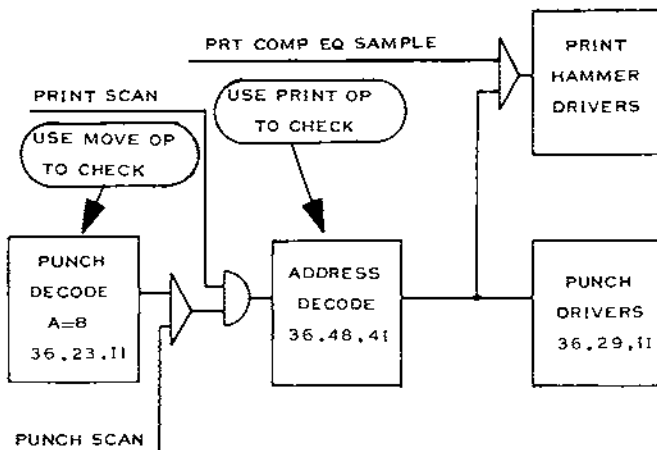

10 DUPLICATE 12 PUNCHES

12 information is duplicated into several cards followed by a correctly punched card. CAUSE - PL 10 fails to make.

11 On PM make certain that the magnet unit latch wick is saturated with #9.

12 Check for a binding condition between latch and latch guide comb. Also, check for wear in the interposer link pivots.

13 Make certain there is .004 to .013 overthrow of the latch to the armature.

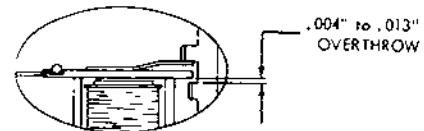

14 The interposer guide bar should be adjusted so that with the punches all the way up there is .007 clearance between the punches and the interposers with the magnets de-energized.

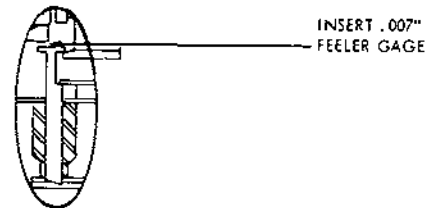

15 Make certain that the punch magnet mounting bars are tight against the top step of their mounting slots and are not twisted or bent.

16 If the material used to bond the reinforcing steel bar to the front end of the yoke extends above the top of the yoke, the armature may fail to seal.

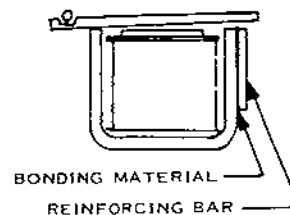

PUNCH UNIT

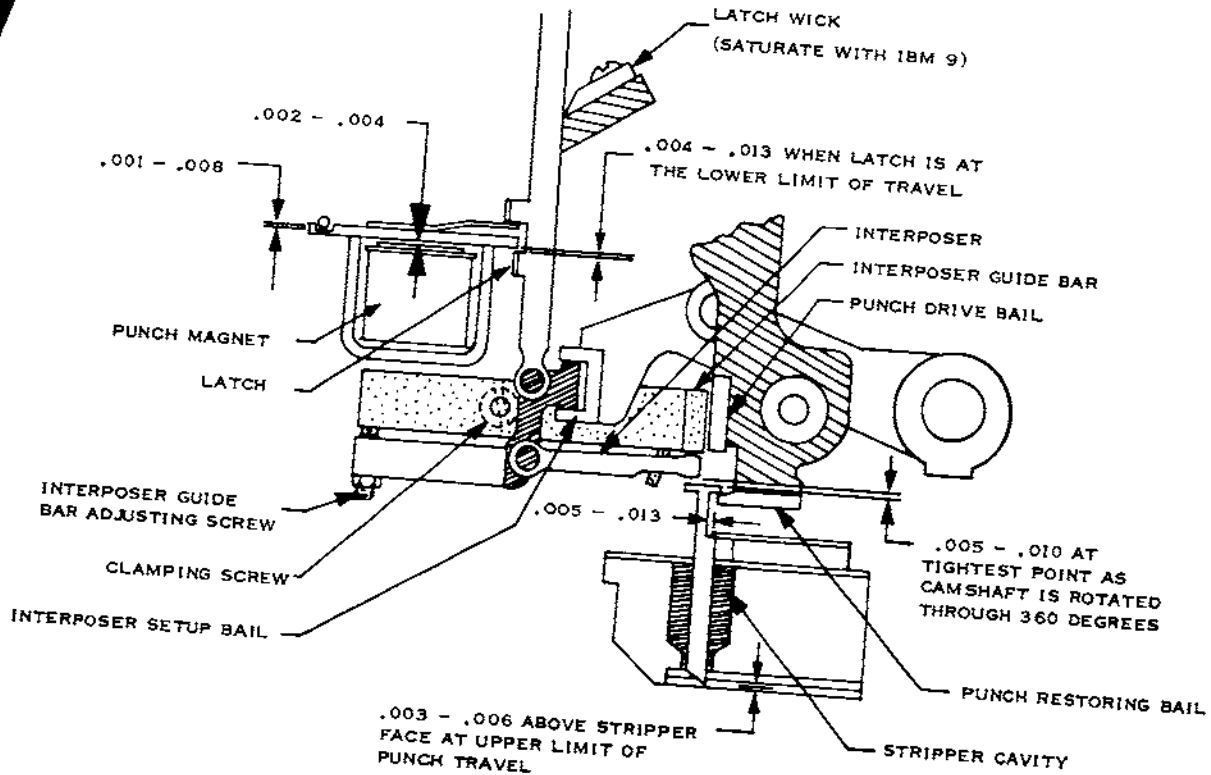

PRINCIPLES OF OPERATION

The punch magnet unit consists of 80 magnets, latches, interposer links, and interposers. The magnets are connected through miniature multi-terminal connectors to the machine circuits.

The cam shaft in the punch drive unit operates continuously when the motor is running. The three-lobed cams operate the interposer setup bail and punch bail three times on each revolution of the punch cam shaft. The punch cam shaft makes 1333 1/3 revolutions per minute.

The interposer setup bail is a U-shaped channel. A projection on each of the 80 interposer links rides in the channel. As the interposer setup bail moves down, all the interposer links move down carrying with them the 80 latches. This pulls each armature against its yoke. If punching is to take place, the magnet is energized at this time. Because the armature did not have to be attracted electrically, very low current is required to keep the armature sealed against its yoke. For this reason, the unit is sometimes referred to as a "no-work" punch unit.

When the interposer setup bail moves up, the magnet just energized keeps its latch in the down position. Because the latch is stationary, the upward movement of the interposer setup bail causes the interposer link to pivot, extending the interposer between the punch drive bail and the punch.

The movement of the punch unit cam shaft then causes the punch bail to move down. Only those columns are punched that have the interposer between the punch drive bail and the punch. When the punch drive bail pushes the interposer down, the interposer is clamped between the punch and the punch drive bail. With this arrangement, the magnet can be de-energized while the punch is going down rather than waiting until the completion of the punching operation.

As the punch bail returns, the interposer is free to be restored by spring tension. On the return stroke of the punch bail, the punch is positively restored by the punch bail.

CAM FOLLOWER UNIT

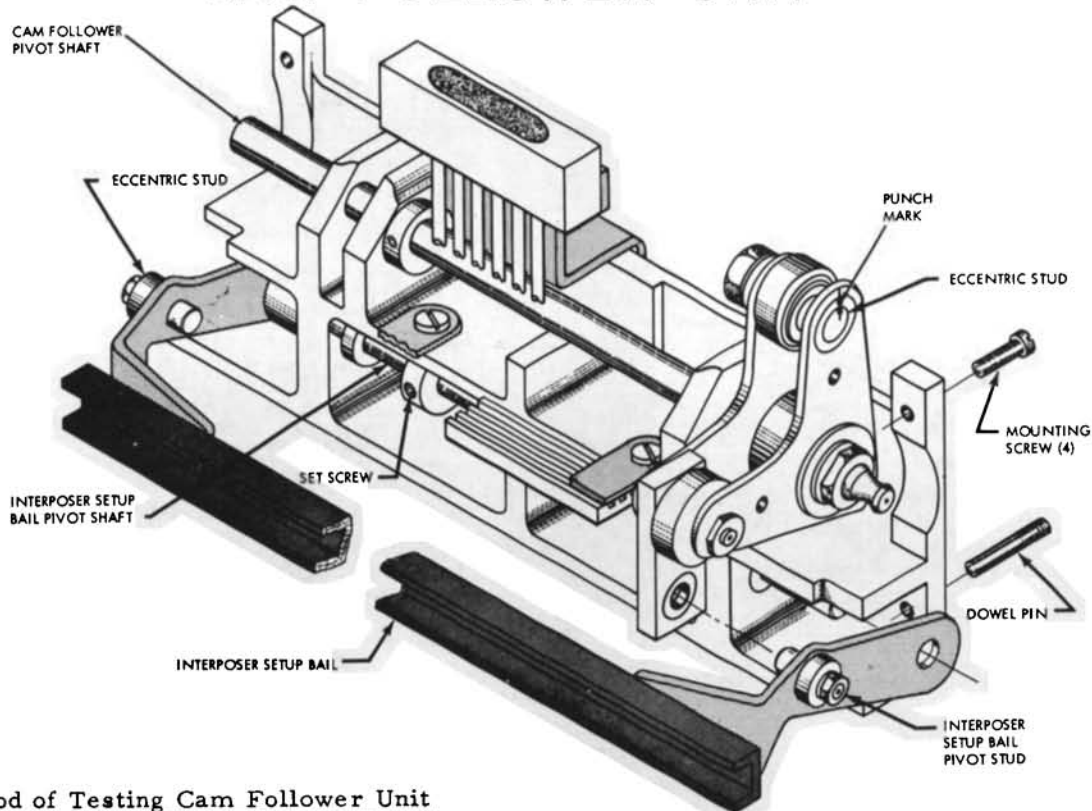

Method of Testing Cam Follower Unit

- 1 Punch 80 columns same digit (200 cards).
- 2 Punch column 1 thru 20 with 12-3-8 punches (200 cards).
- 3 Punch column 61 thru 80 with 12-3-8 punches (200 cards).

This will operate punch unit under loading conditions.

THE CAM FOLLOWER UNIT MUST BE REMOVED IN ORDER TO CHECK FOR WEAR. This may be accomplished by removing the stripper assembly, pulling the two dowel pins in cam follower mounting plate (they must be completely removed to allow the set-up bail to clear the interposer guide bar), and removing the four mounting screws.

SERVICE CHECKS

With the cam follower unit removed from the punch drive unit check:

- 1 That the four collars on the pivot shaft are tight against inner race of the pivot bearings.
- 2 That set screws holding cam follower pivot shaft, interposer bail pivot studs, and interposer set-up bail pivot shaft are tight.

- 3 That nuts on all cam follower bearing shafts and interposer set-up bail pivot studs are tight.
- 4 For wear, fretting corrosion, or lack of lubrication of all parts.

Bench check parallelism of set-up bail with gauge #600914. Refer to reference manual for complete procedure. Also, check cam follower bearing adjustment per reference manual.

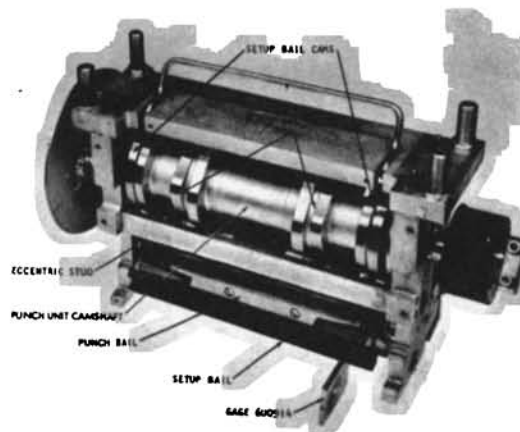

INPUT OUTPUT DATA FLOW

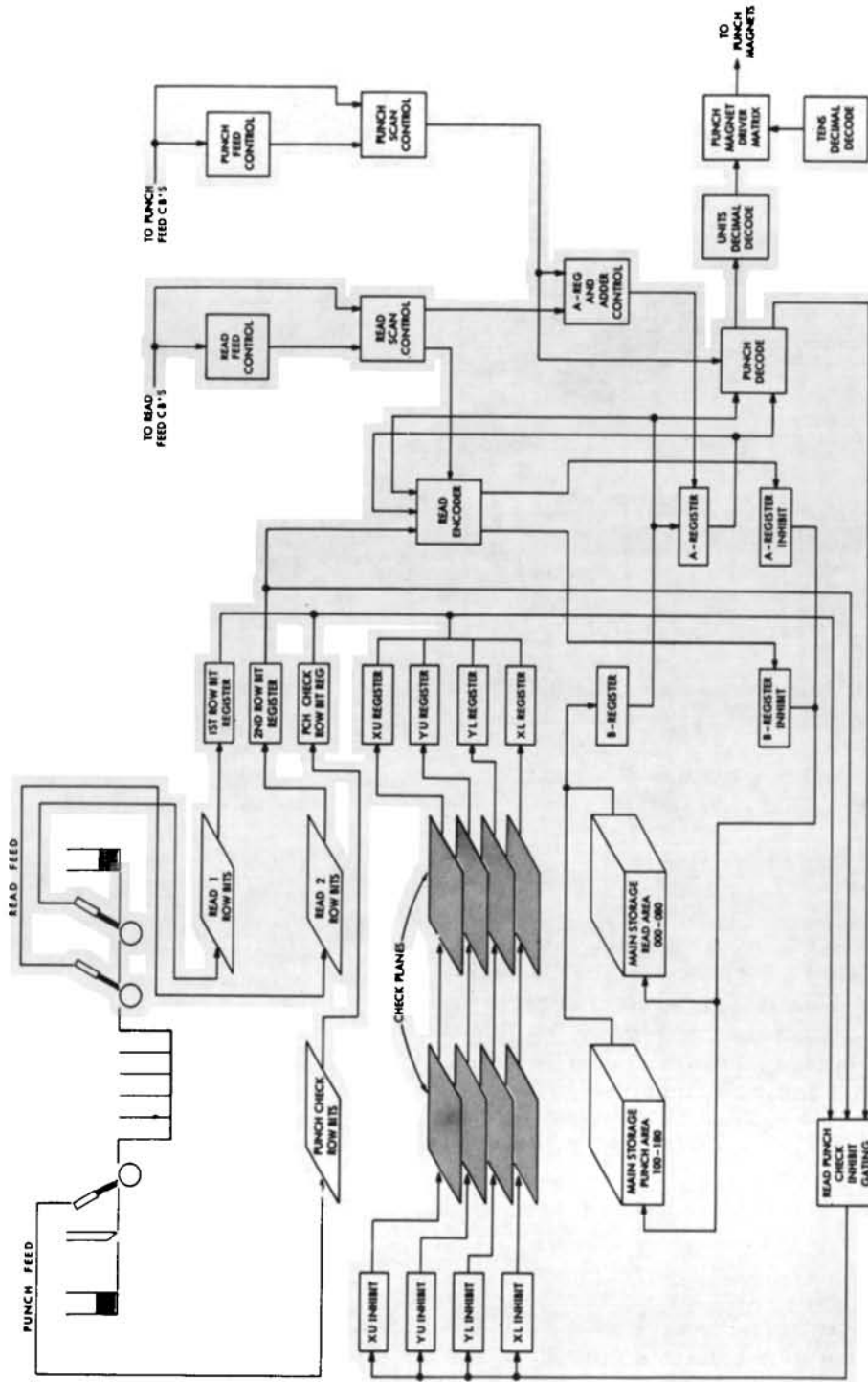

Read Punch Data Flow

LIGHTS

UNIT	ERROR	LATCH INVOLVED	MACHINE STOPS I O CHECK STOP SWITCH ON	LIGHTS ON WHEN STOPPED	RESET BY	REMARKS
READER	READ CHECK	READ CHECK (36,14,11)	AT THE END OF THE FEED CYCLE	READ CHECK (1402) READ (PROCESS)	CHECK RESET KEY ON THE 1402	CARDS MUST BE RUN OUT BEFORE CHECK RESET KEY BECOMES EFFECTIVE.
READER	VALIDITY	VALIDITY (36,14,11)	AT THE END OF THE FEED CYCLE	VALIDITY (1402) READ (PROCESS)	CHECK RESET KEY ON THE 1402	CARDS MUST BE RUN OUT BEFORE CHECK RESET KEY BECOMES EFFECTIVE.
		NOTE ---- ALSO IF THE INVALID COMBINATION CAUSES INCORRECT PARITY		STORAGE (PROCESS) PROCESS (PROCESS) CHECK RESET (PROCESS)	CHECK RESET KEY ON THE PROCESSOR	
READER	JAM	PICKS RA	AT THE END OF THE FEED CYCLE	READER STOP (1402) READ (PROCESS)	CHECK RESET KEY ON THE 1402	CARDS MUST BE RUN OUT BEFORE CHECK RESET KEY BECOMES EFFECTIVE.
PUNCH	PUNCH CHECK	PUNCH CHECK (36,14,11)	AT THE END OF THE FEED CYCLE	PUNCH CHECK (1402) PUNCH (PROCESS)	CHECK RESET KEY ON THE 1402	
PUNCH	PARITY	PUNCH STOP B REG CHECK	AT THE END OF THE FEED CYCLE	PUNCH (PROCESS) PROCESS (PROCESS) B REG (PROCESS) CHECK RESET (PROCESS)	CHECK RESET KEY ON THE 1401	
PUNCH	JAM	RELAY 31 PUNCH STOP	AT THE END OF THE FEED CYCLE	PUNCH STOP (1402) PUNCH (PROCESS)	CHECK RESET KEY ON THE 1402	CARDS MUST BE RUN OUT BEFORE CHECK RESET KEY BECOMES EFFECTIVE.

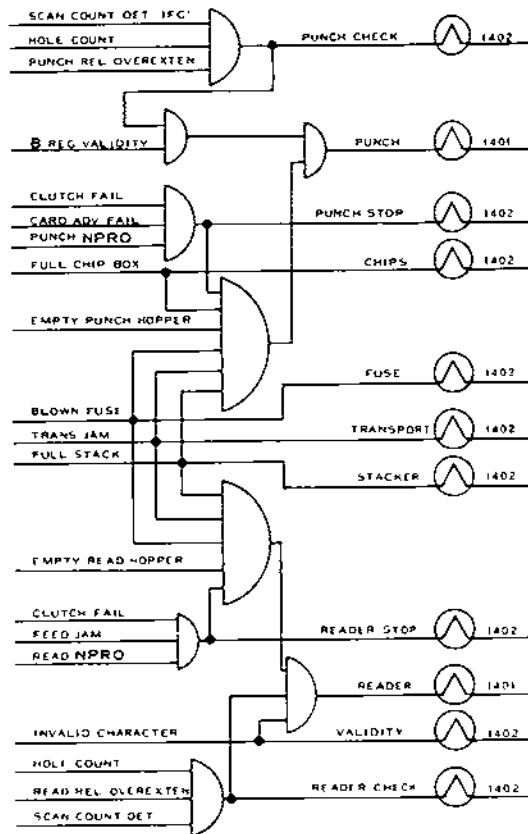

READ START AND RUN

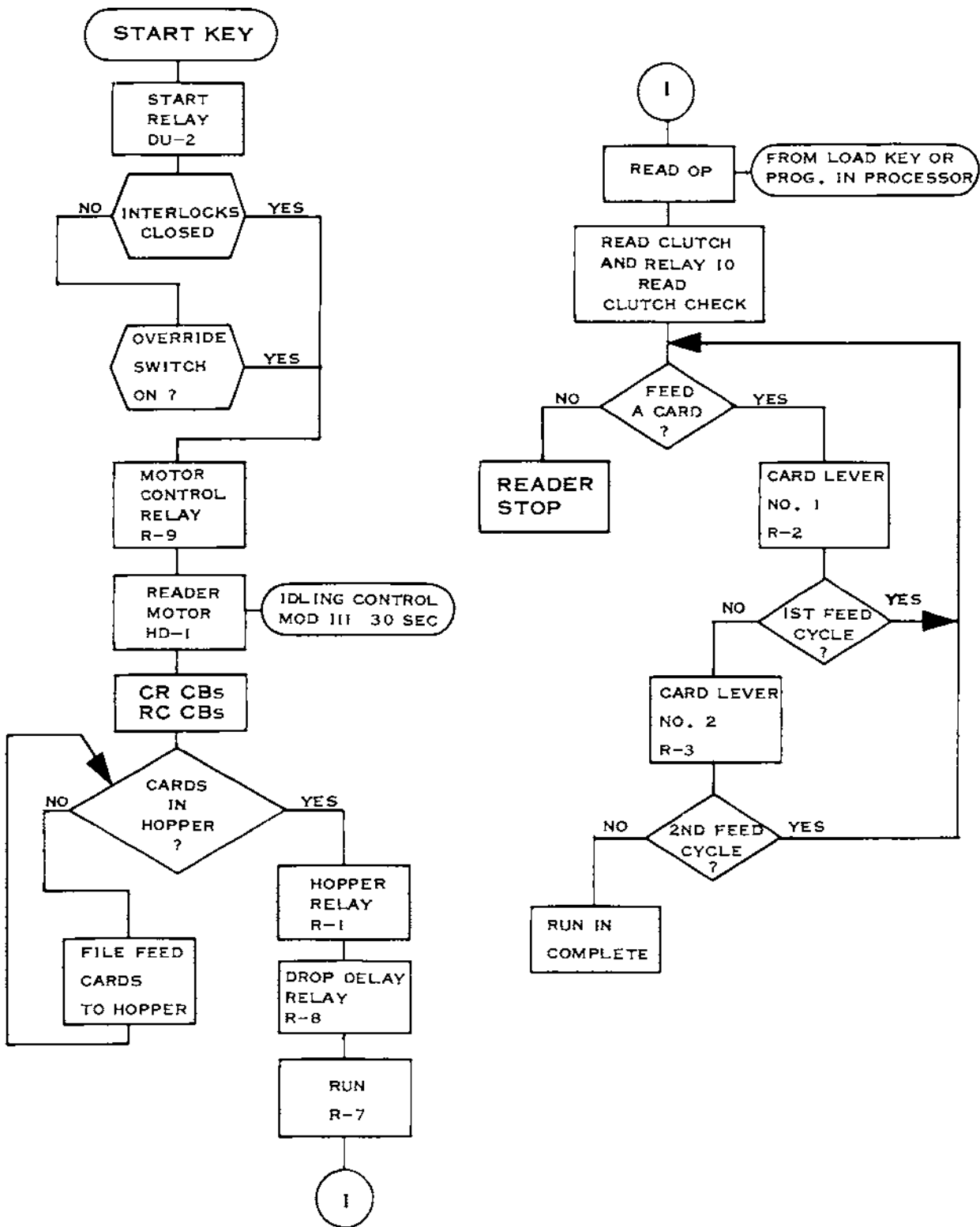

RUN IN - NOT EARLY READ

FIRST THREE CYCLES TO READ THE FIRST CARD
THEN PROGRAM CONTROL
WIRING DIAGRAM 609400V

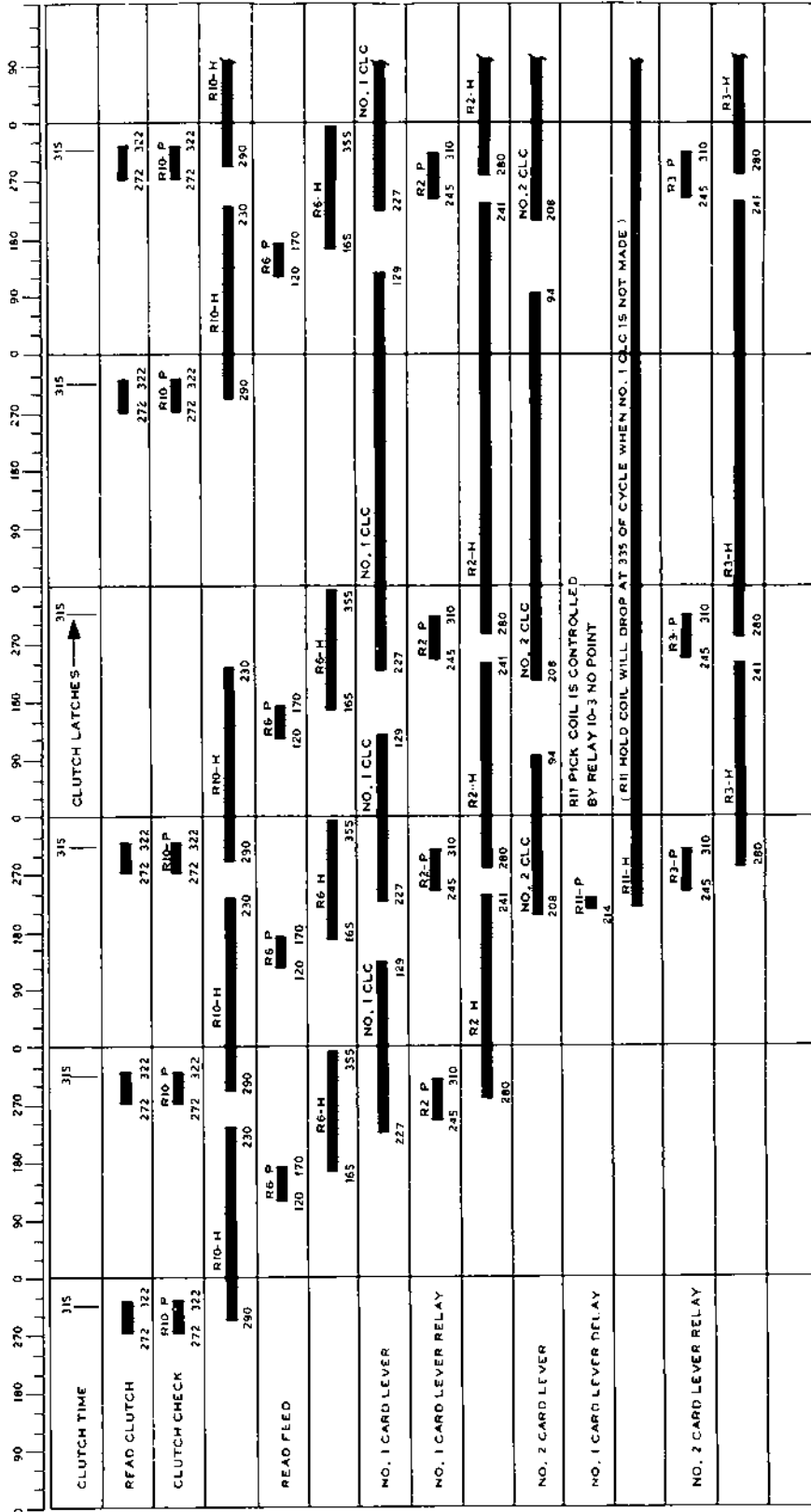

SYNC SWITCH ON
FIRST THREE CYCLES TO READ THE FIRST CARD
THEN PROGRAM CONTROL

RUN IN - EARLY READ

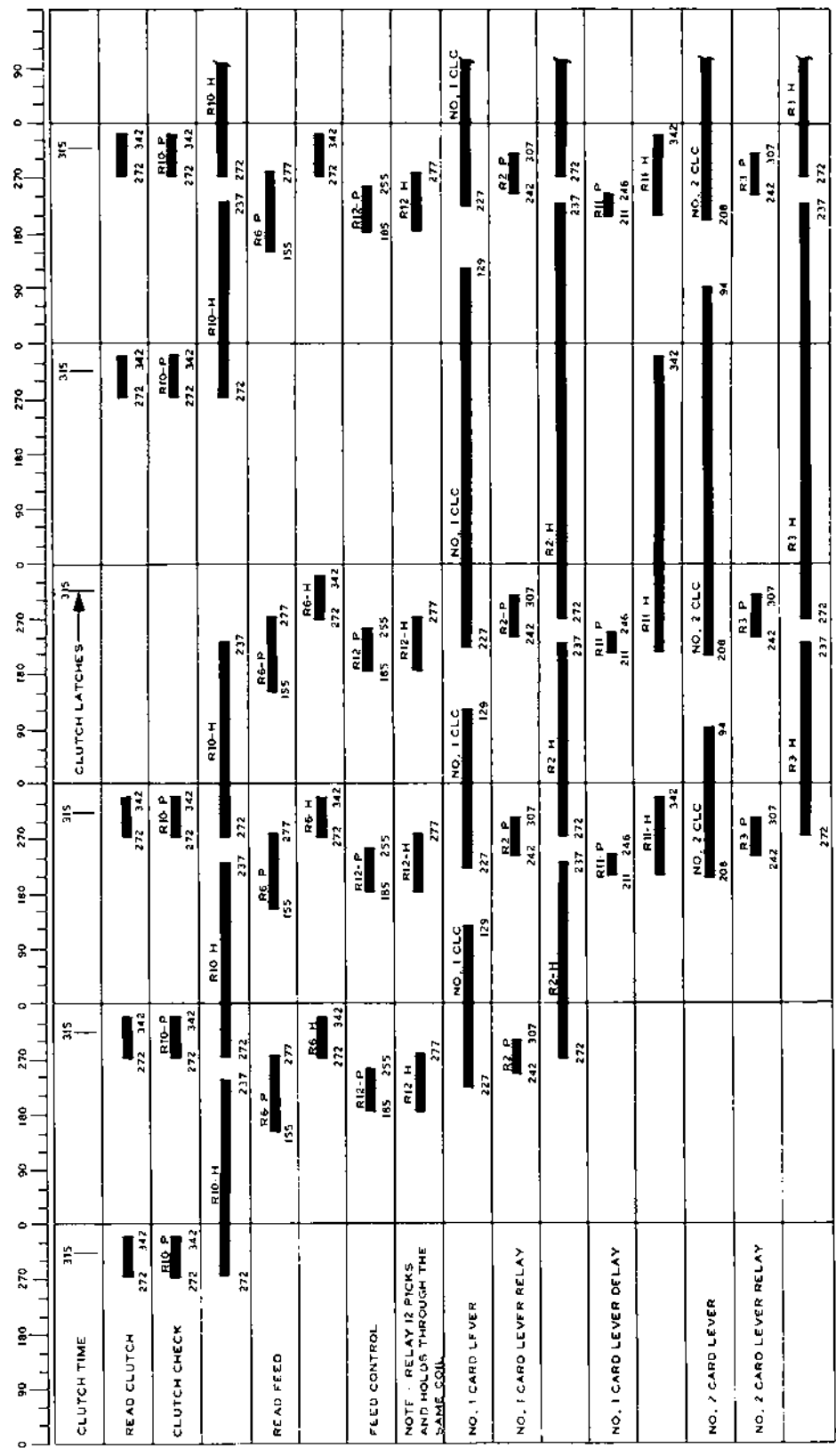

RUN OUT - NOT EARLY READ

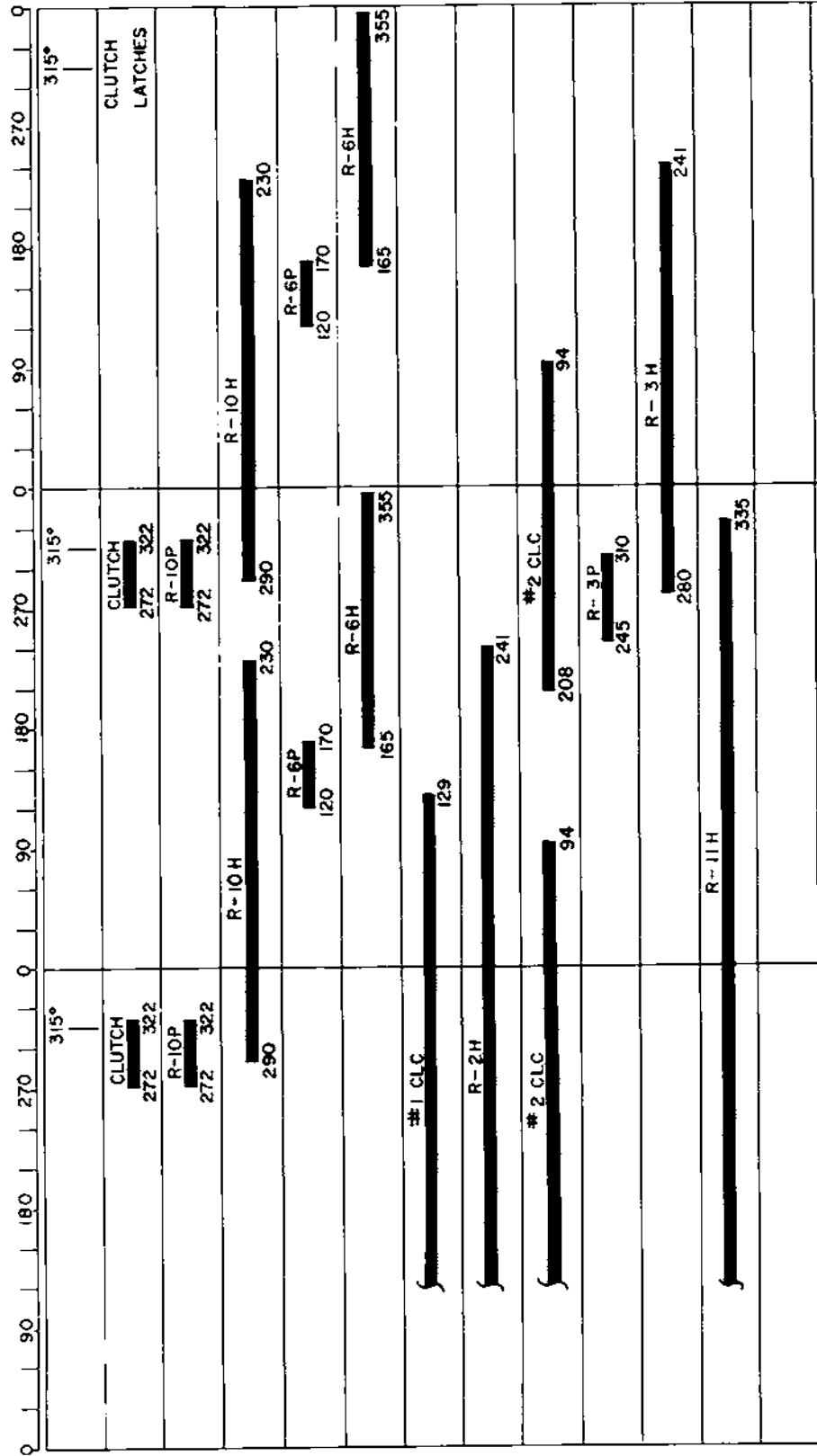

RUN OUT - EARLY READ

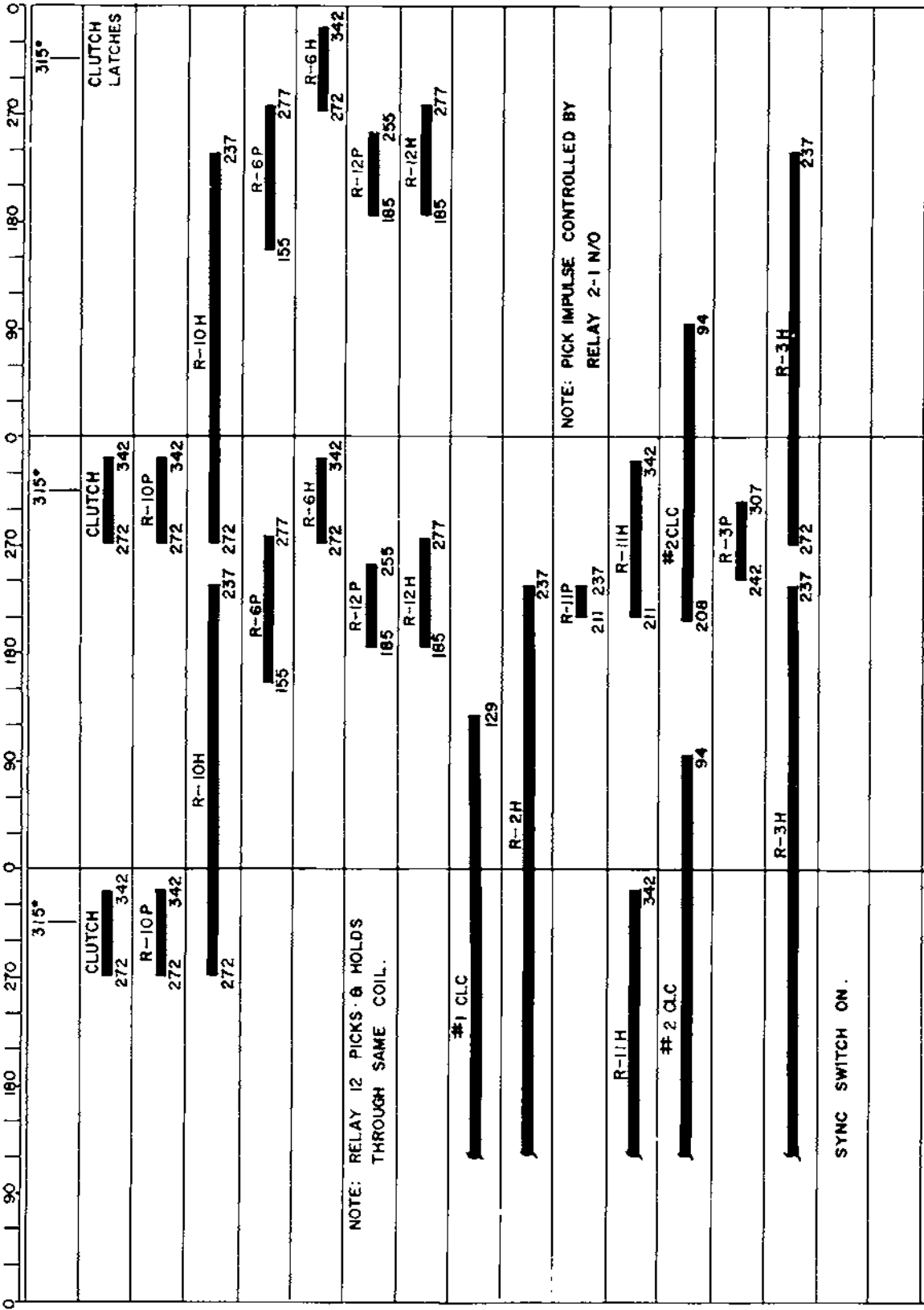

READ OP CONDENSED LOGIC

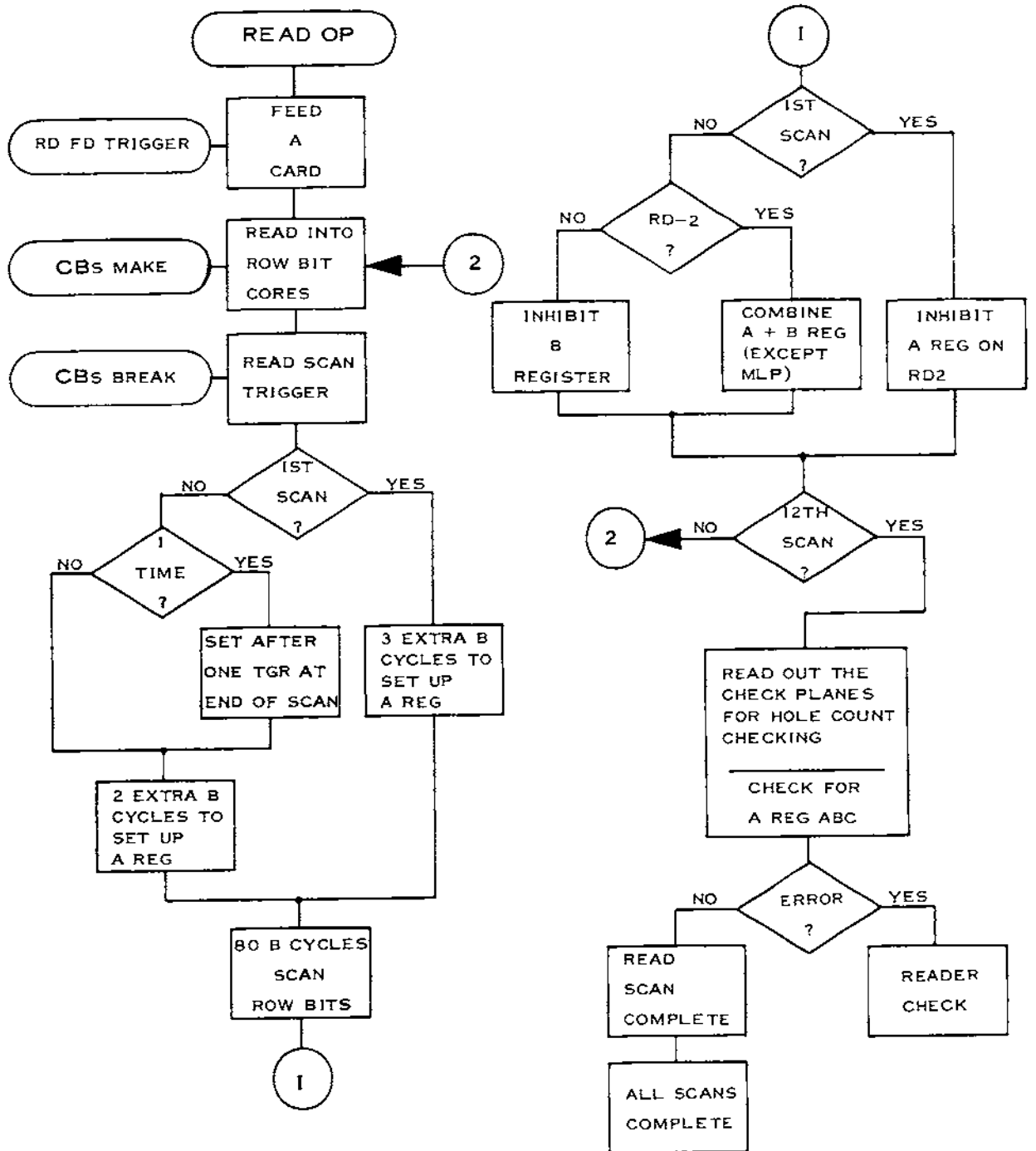

READ OP LOGIC FLOW

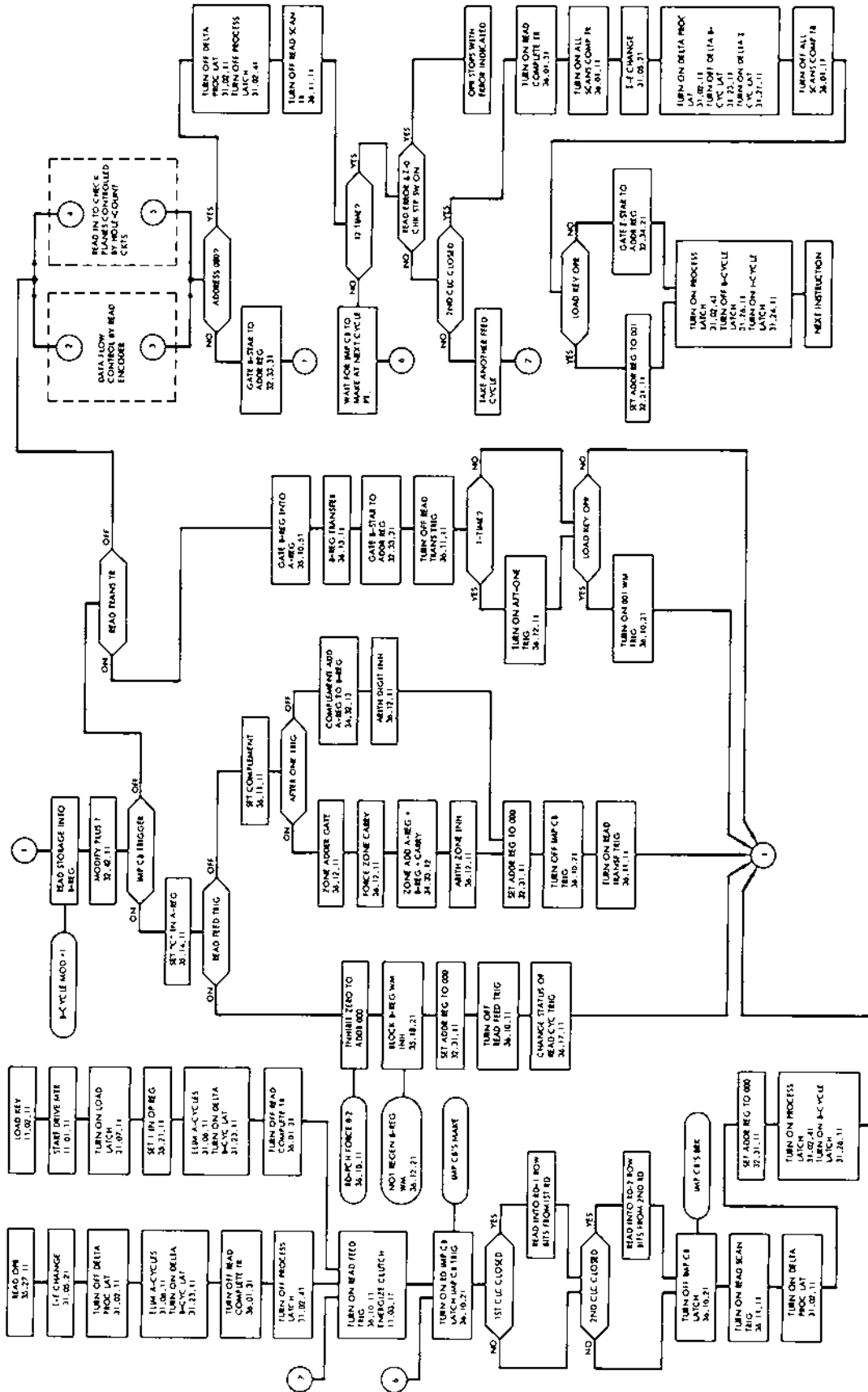

READ OP LOGIC FLOW

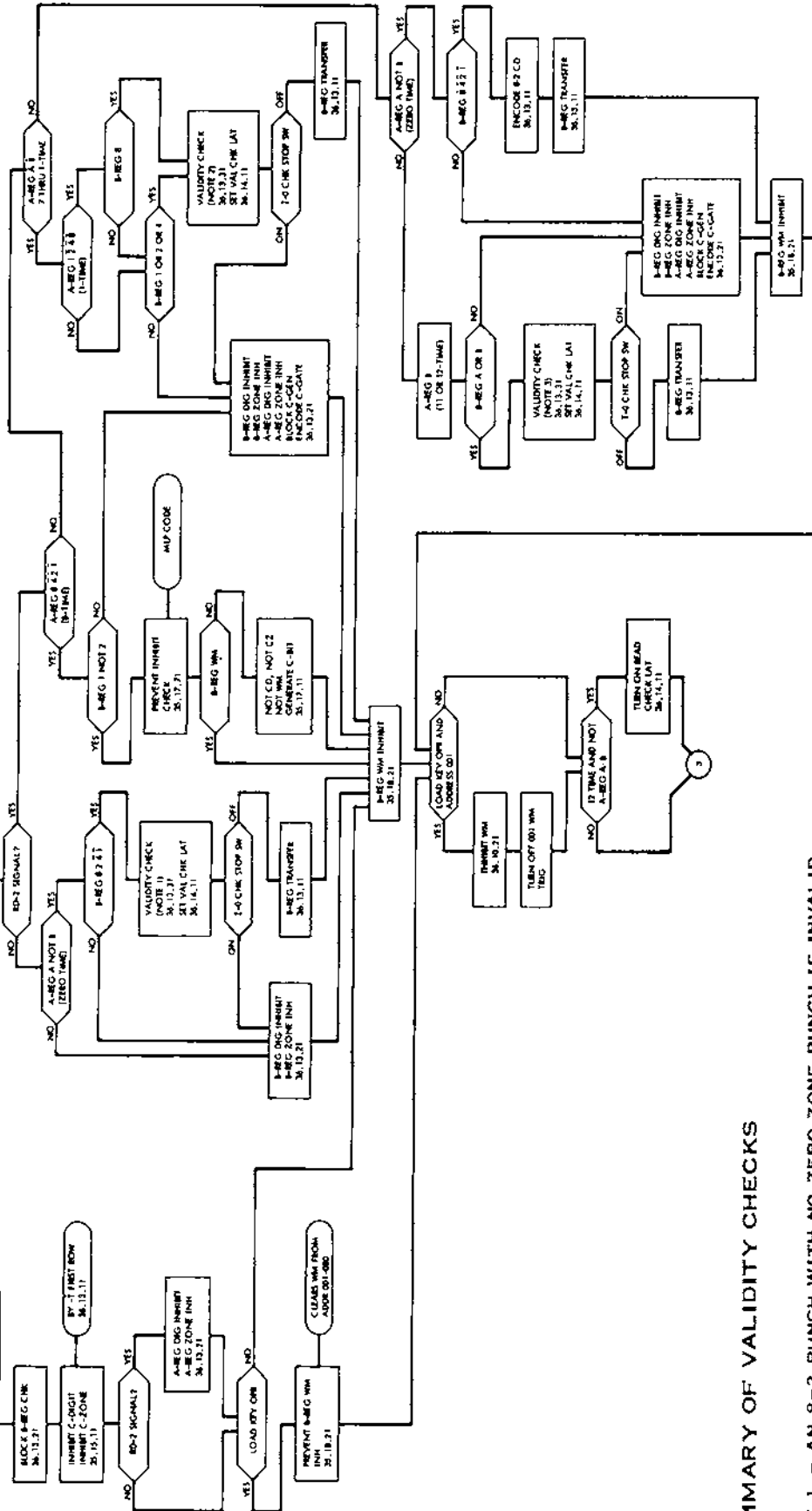

Read Operation, Load Key, Hole Count (Part 2 of 3)

SUMMARY OF VALIDITY CHECKS

- NOTE 1 - AN 8-2 PUNCH WITH NO ZERO ZONE PUNCH IS INVALID.
- NOTE 2 - ANY DOUBLE-NUMERIC PUNCH IS INVALID WITH FOLLOWING EXCEPTIONS:
 - 8-7, 8-6, 8-5, 8-4, 8-3, 8-2-0, 9-8, 9-8 WITH ANY ONE OTHER NUM. PUNCH.
- NOTE 3 - ANY DOUBLE-ZONE PUNCH IS INVALID WITH FOLLOWING EXCEPTIONS:
 - 0-11 WITH NO NUMERIC PUNCH, 0-12 WITH NO NUMERIC PUNCH, 9-8-0-11, 9-8-0-12.

A REGISTER SETUP FOR READ OP

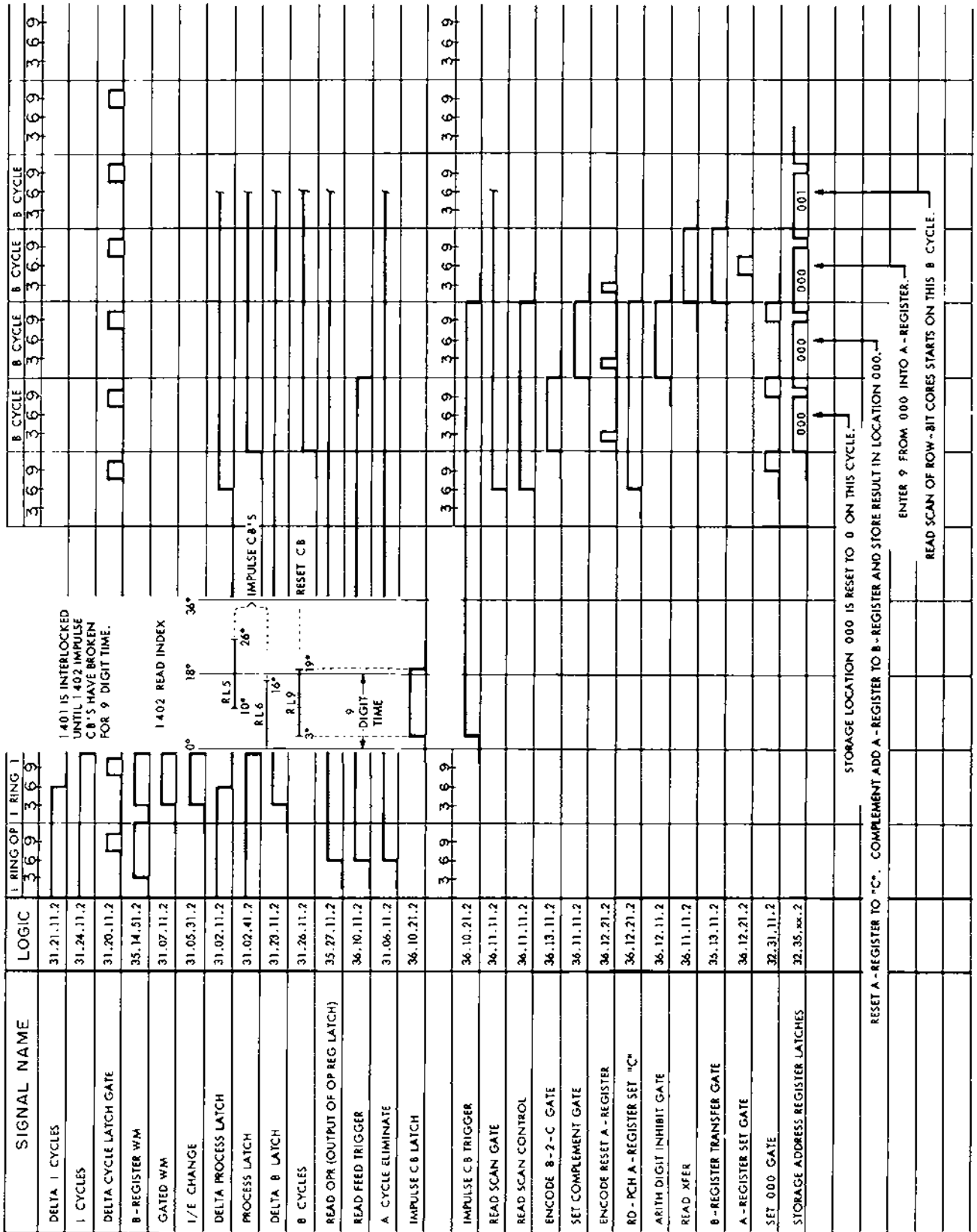

HOLE COUNT

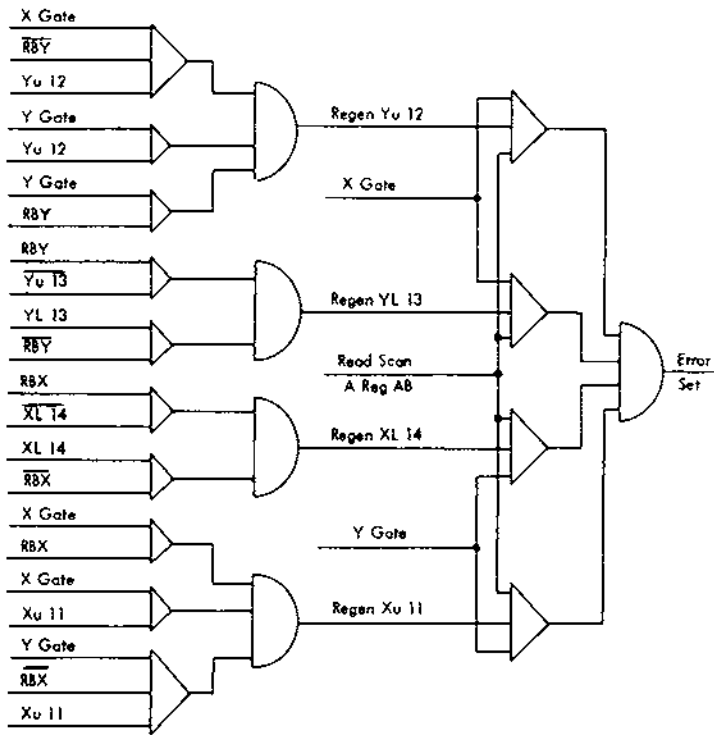

CHECK PLANE SCOPING HINTS

Proper regeneration can be checked by syncing on X or Y gate. The cards used should contain all the same character and should be run on a read and branch instruction.

To see the entire check plane operation for one card, it is necessary to display two card feed cycles.

If a 561 or 535 scope is available, it is possible to sync the normal sweep on X or Y gate, set the sweep to display two cycles, and then sync the delayed sweep on either address stop to display a particular b cycle or a A reg combined bits to display a particular scan.

When scoping the check planes with a 310, it will be necessary to build a sync by ANDing X or Y gate, a particular scan, and address stop in order to display a single digit in a single column.

The figure below represents the operation of the X_u and X_l check planes while reading a column which contains a zero and a seven punch. Note that the upper plane only senses the first hole read at each set of brushes while the lower plane flips back and forth with each hole read.

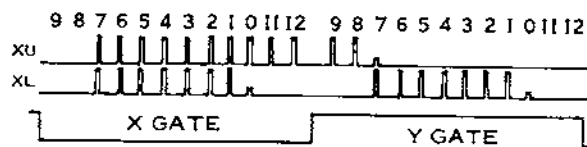

READ HOLE COUNT CHECKING

Since two cards are being read simultaneously (one at 1st read and one at 2nd read), it is necessary to provide duplicate sets of check planes and associated circuitry.

An alternate cycle trigger is used to alternately bring up X gate and Y gate in the following manner.

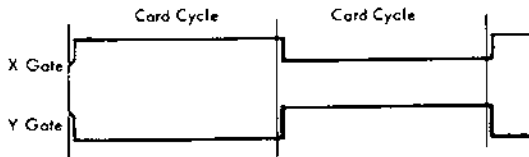

There are two sets of X planes, X_U and X_1 , and two sets of Y planes, Y_U and Y_1 . If a card enters 1st read while the X gate is up, it will be checked by the X_U and X_1 planes; if it enters 1st read while the Y gate is up, it will be checked by the Y_U and Y_1 planes.

To simplify analysis, follow one card through 1st and 2nd read. Let us assume that X gate is up when it passes 1st read. Y gate will then be up when it passes 2nd read.

Analyzing the following piece of logic, it can be seen that we are concerned with RBX only.

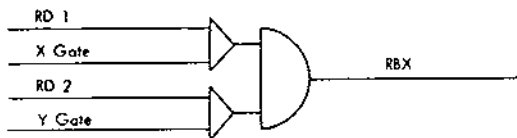

Let us now analyze plane X_1 14 operation.

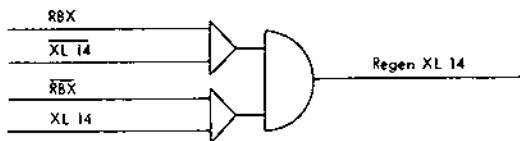

From the above, it can be seen that a core will be set in the X_1 14 plane the first time a row bit is sensed and will be regenerated until a second row bit is sensed. If a card has one punch in a particular column, the core in the X_1 plane at the address corresponding to that column will be set to 1 on the scan in which the RBX is sensed. With one punch in the column, this would occur when the hole was sensed at second read brushes.

The X_U plane is gated differently than the X_1 plane. Note the following piece of logic.

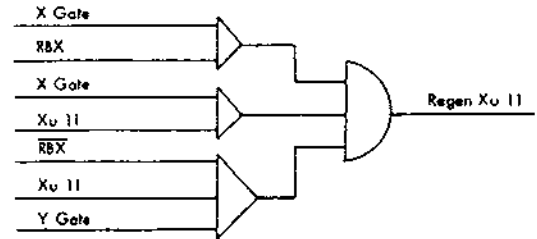

From the above, it can be seen that for any punched column in a card, the first hole that is read will result in the corresponding X_U core being set to 1. It can also be seen that the core will be regenerated each time it is readdressed while passing 1st read. This will be true whether a particular column has one or more holes. When the card is passing 2nd read and Y gate is up, the core will continue to be regenerated until an RBX is sensed. No further regeneration can then occur.

Summarizing the above, the following conditions should be true during proper operation:

If X gate is up when the card passes 1st read, the Y gate will be up when it passes 2nd read.

For each hole read at 1st and 2nd read, an RBX will be sensed.

A position in the X_1 plane will alternate between 1 and 0 for each hole read in the corresponding column of the card.

A position in the X_U plane will be set to 1 for the first hole read at 1st read and will be regenerated until the first hole is read at 2nd read. It will then remain at 0 for the remainder of the card.

If either the X_U or X_1 plane is regenerating during the last scan when Y gate is up, an error condition exists. This means that either a hole was misread or the circuitry is not functioning properly.

A card entering 1st read when Y gate is up would be checked in a manner similar to the above. However, it would be checked by the Y_U and Y_1 planes.

READ COLUMN BINARY

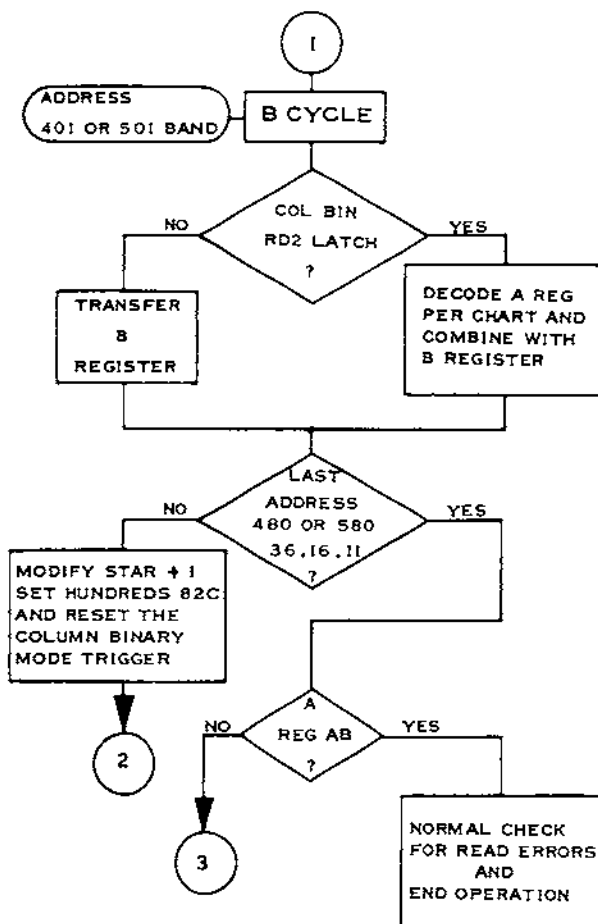
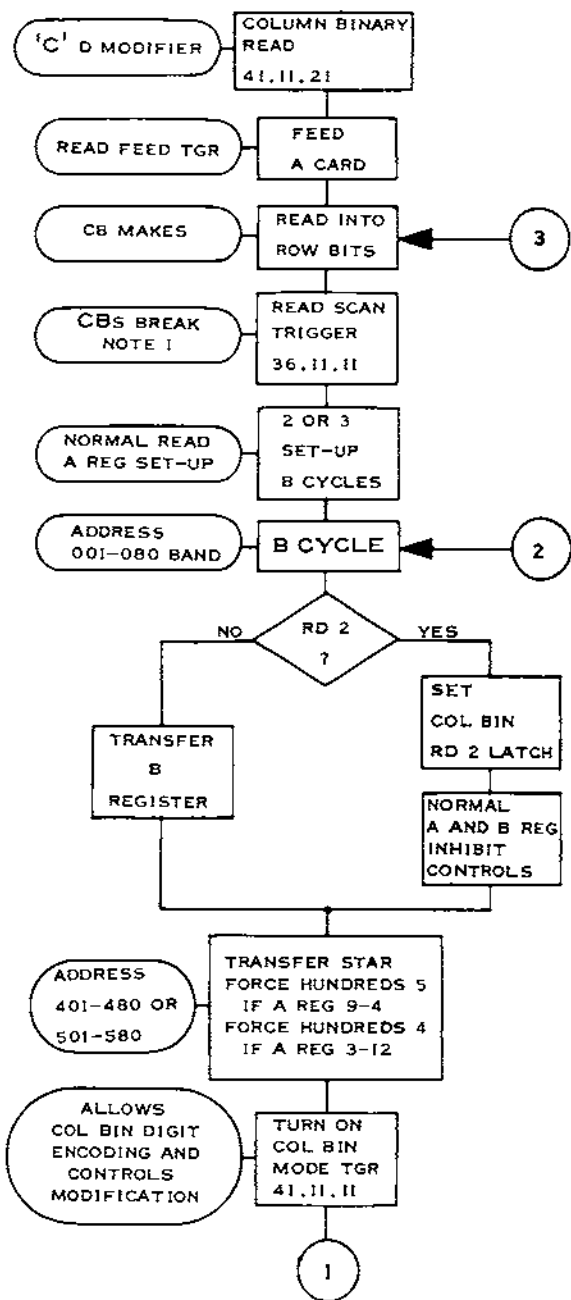

A REG	BIT STORED	ADDRESS
9	1	501 TO 580
8	2	
7	4	
6	8	
5	A	
4	B	401 TO 480
3	1	
2	2	
1	4	
0	8	
11	A	
12	B	

NOTE - COLUMN BINARY OPERATION REQUIRES 160 B CYCLES FOR EACH DIGIT TIME .

NOTE 1 - DIGIT IMPULSES MUST NOT BE LONGER THAN 3 DEGREES . THIS ALLOWS 2500 US FOR THE 160 B CYCLE SCANS .

PUNCH START AND RUN

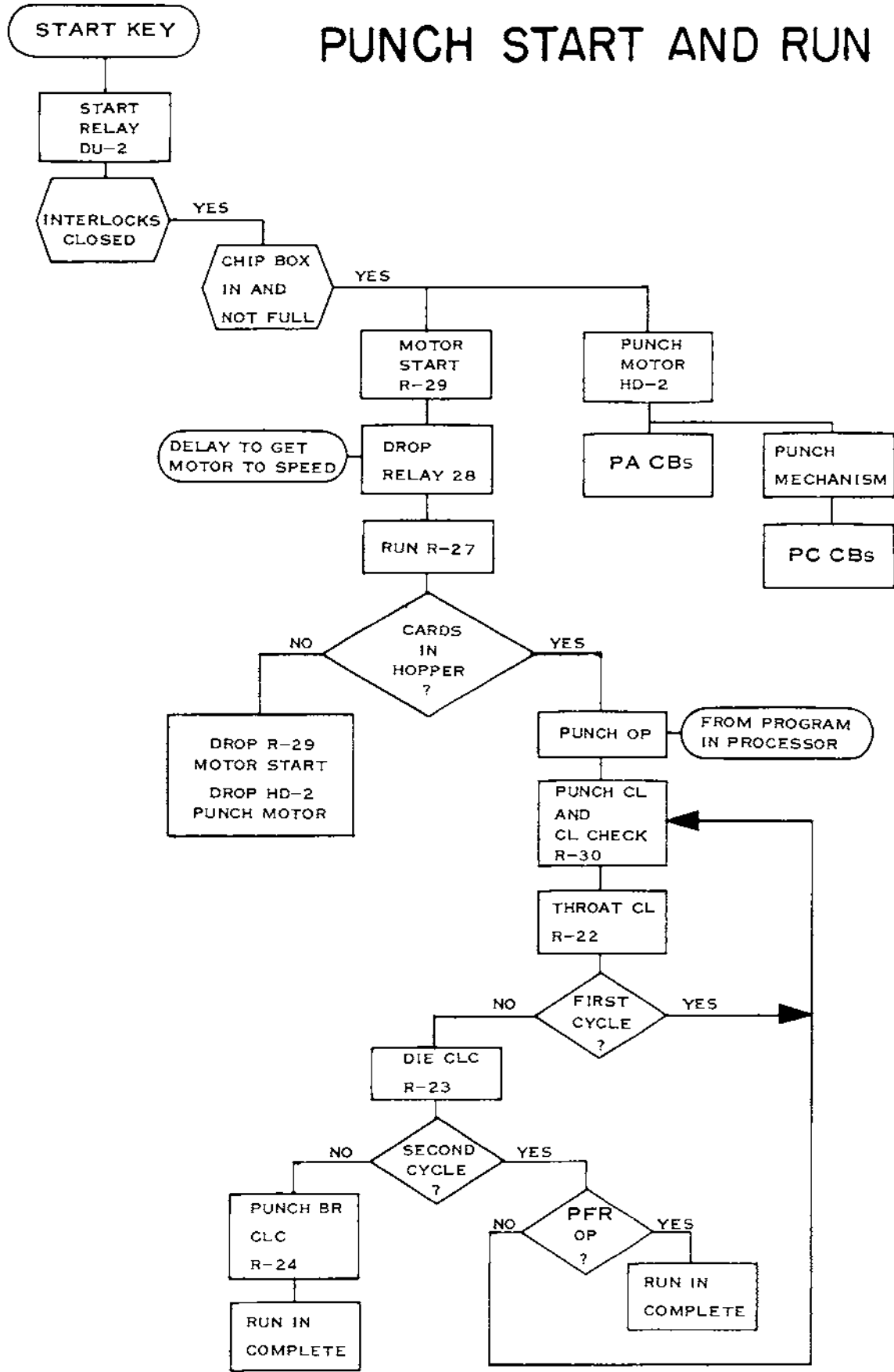

PUNCH OP CONDENSED LOGIC

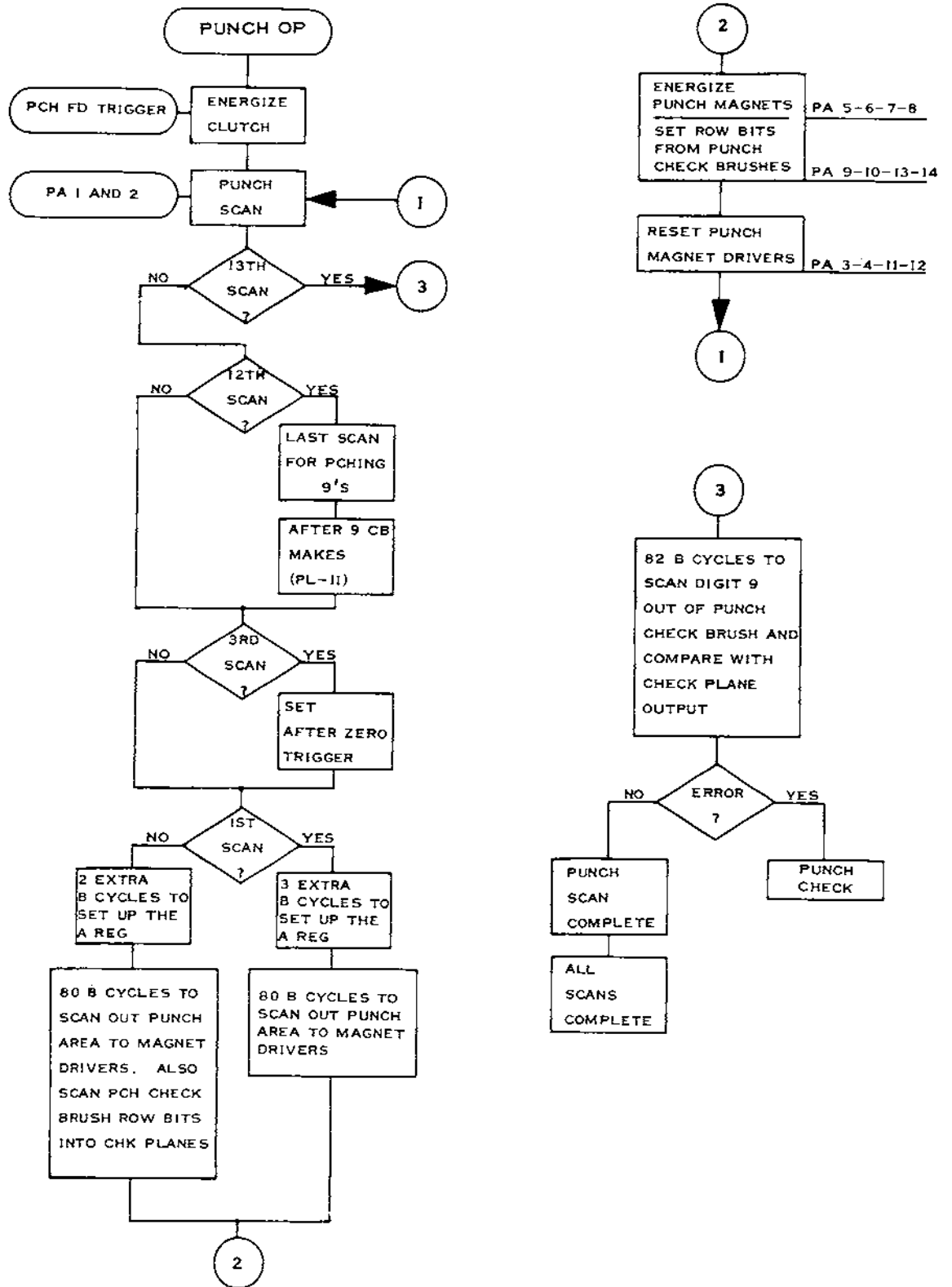

PUNCH OP LOGIC FLOW

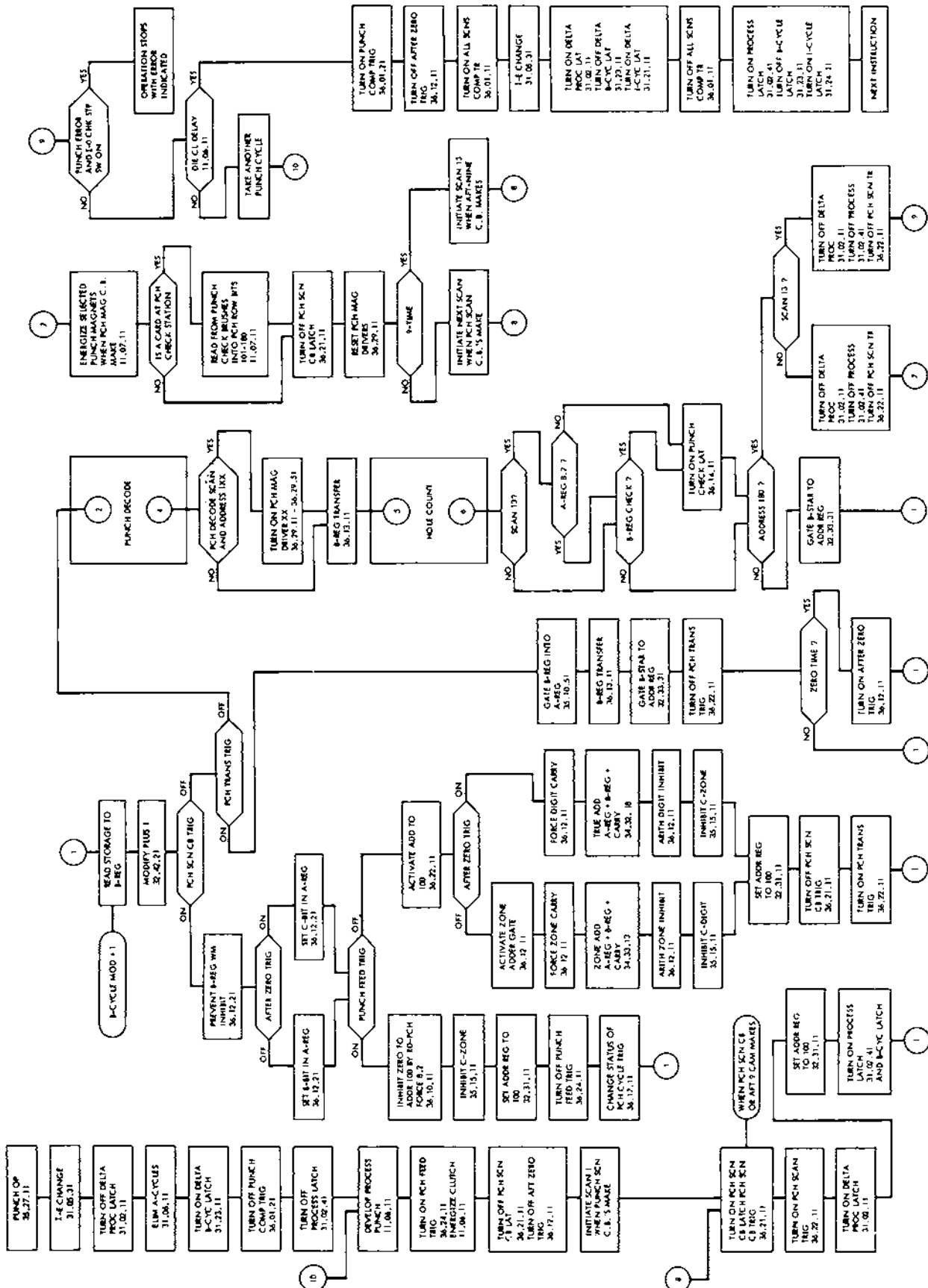

Punch Operation, Hole Count (Part 1 of 3)

PUNCH OP LOGIC FLOW

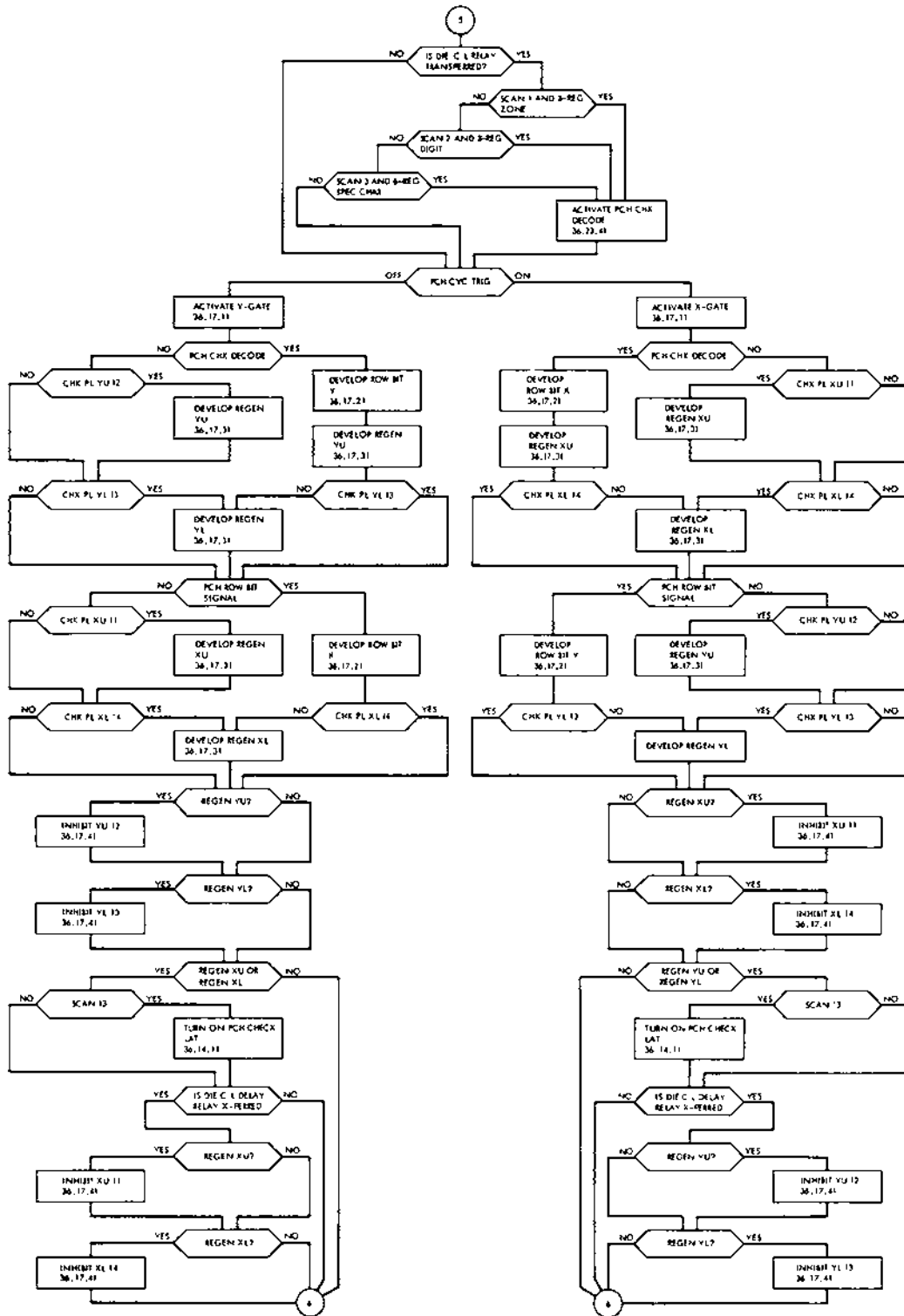

Punch Operation, Hole Count (Part 3 of 3)

A REGISTER SETUP FOR PUNCH OP

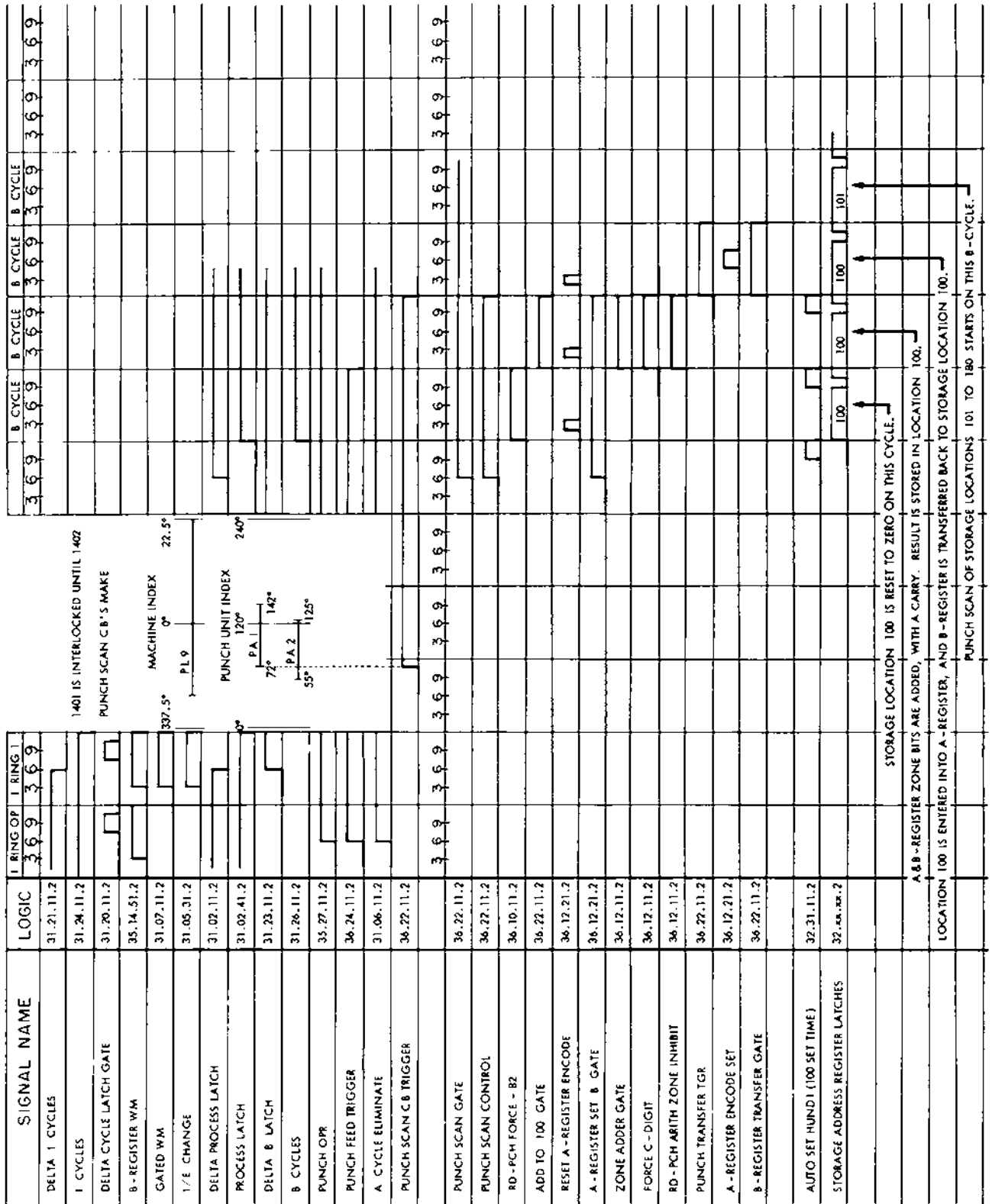

PUNCH COLUMN BINARY

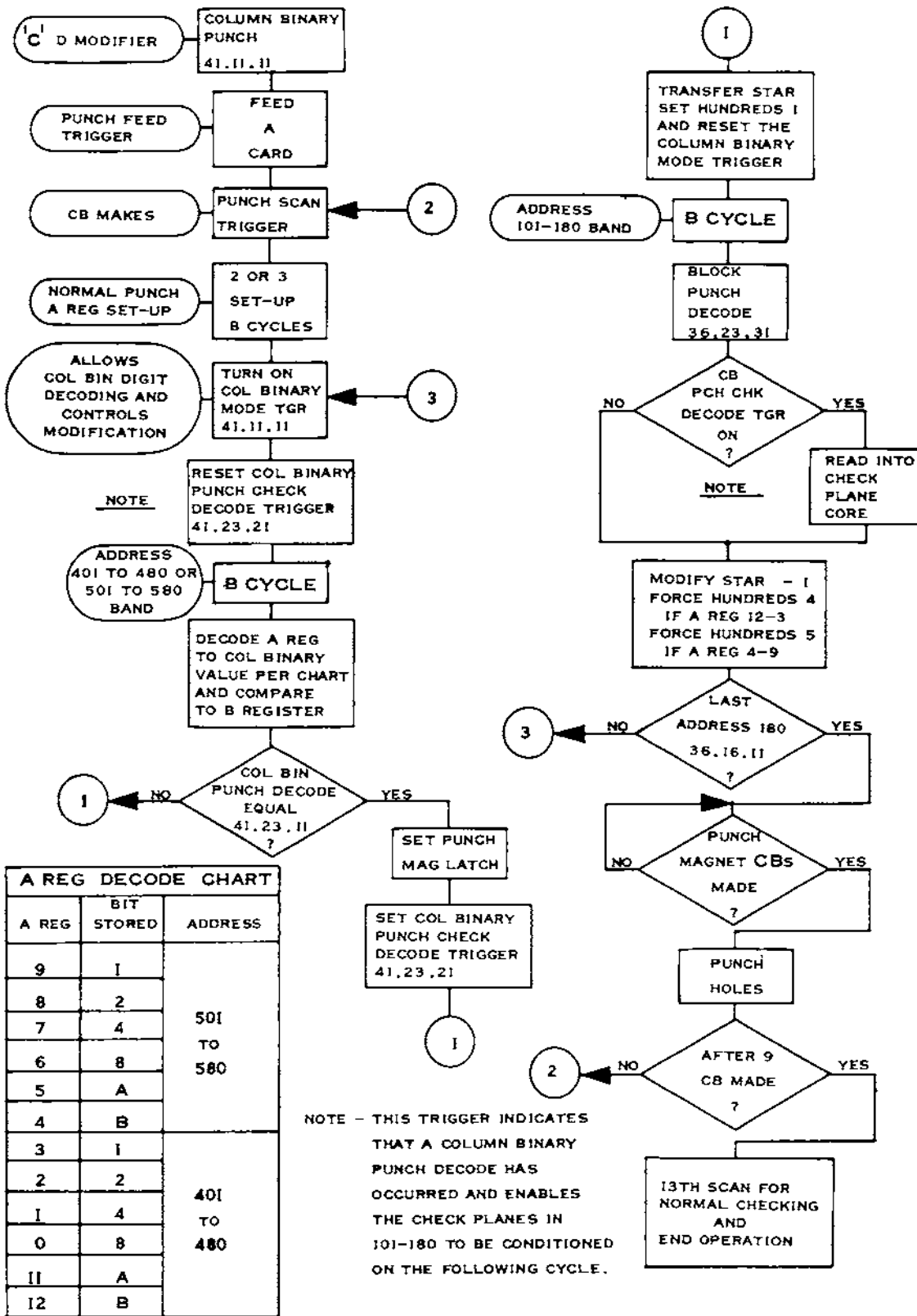

PFR READ AND PUNCH SCANS

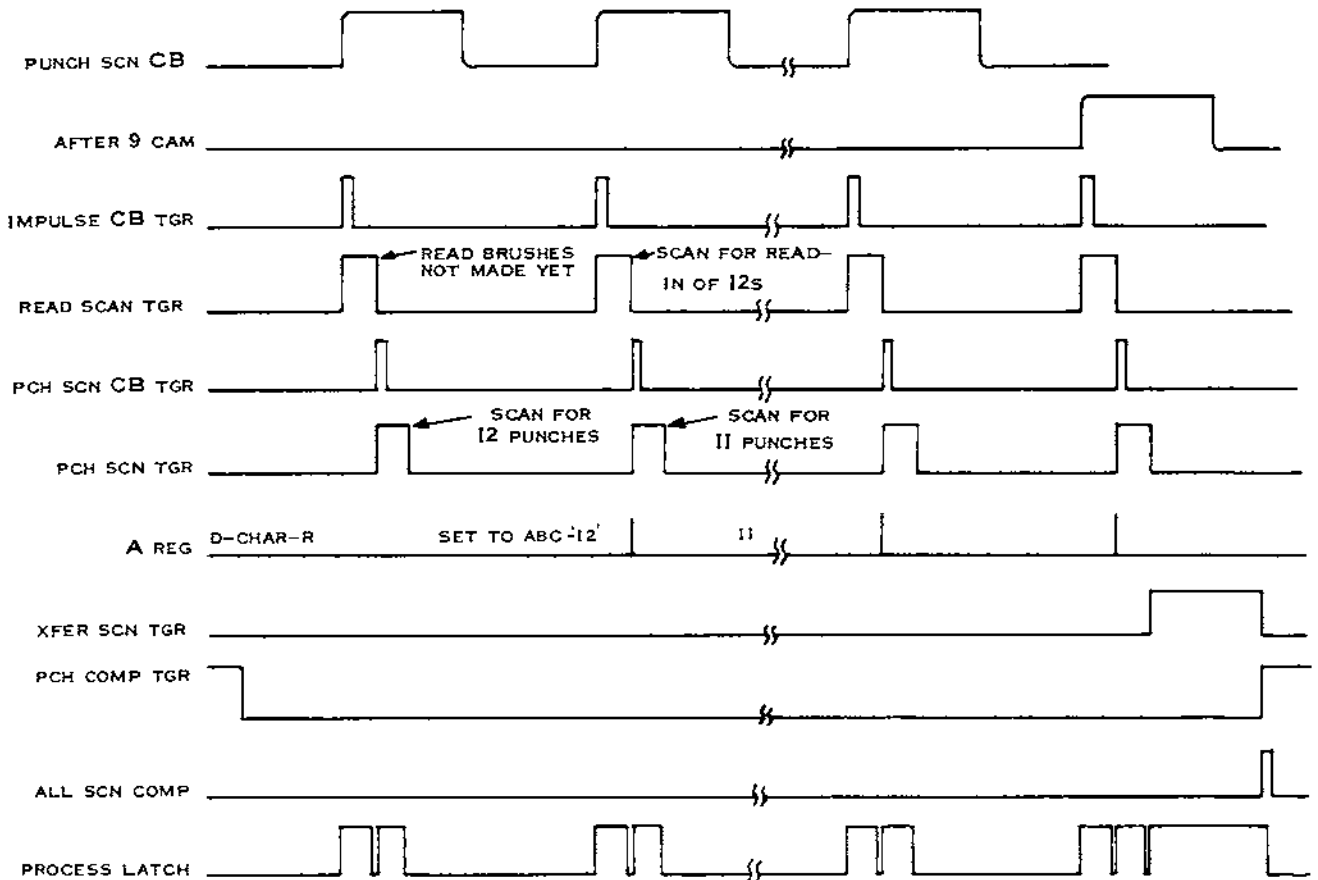
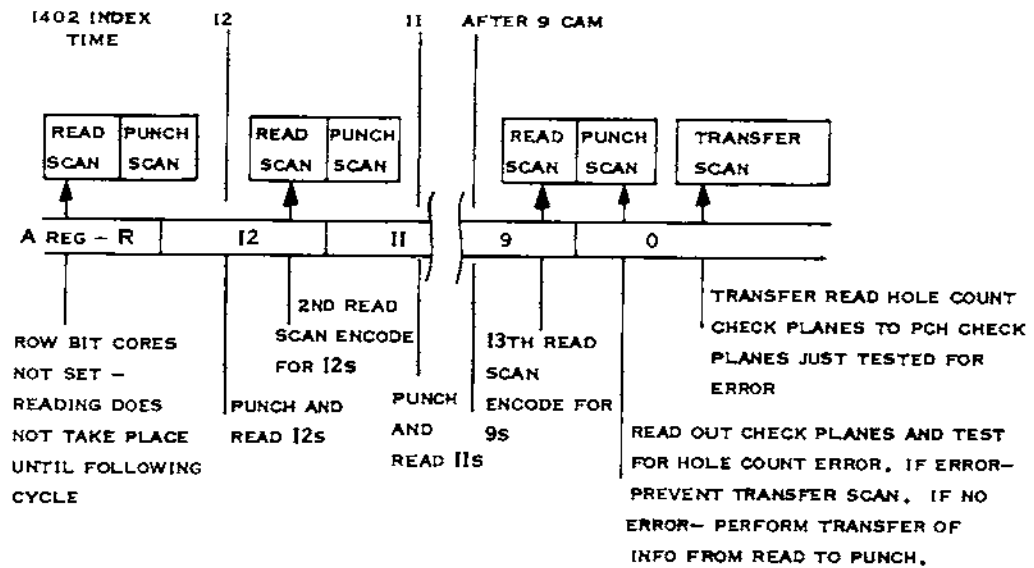

PFR SCAN TIMING RELATIONSHIP

PFR OPERATION

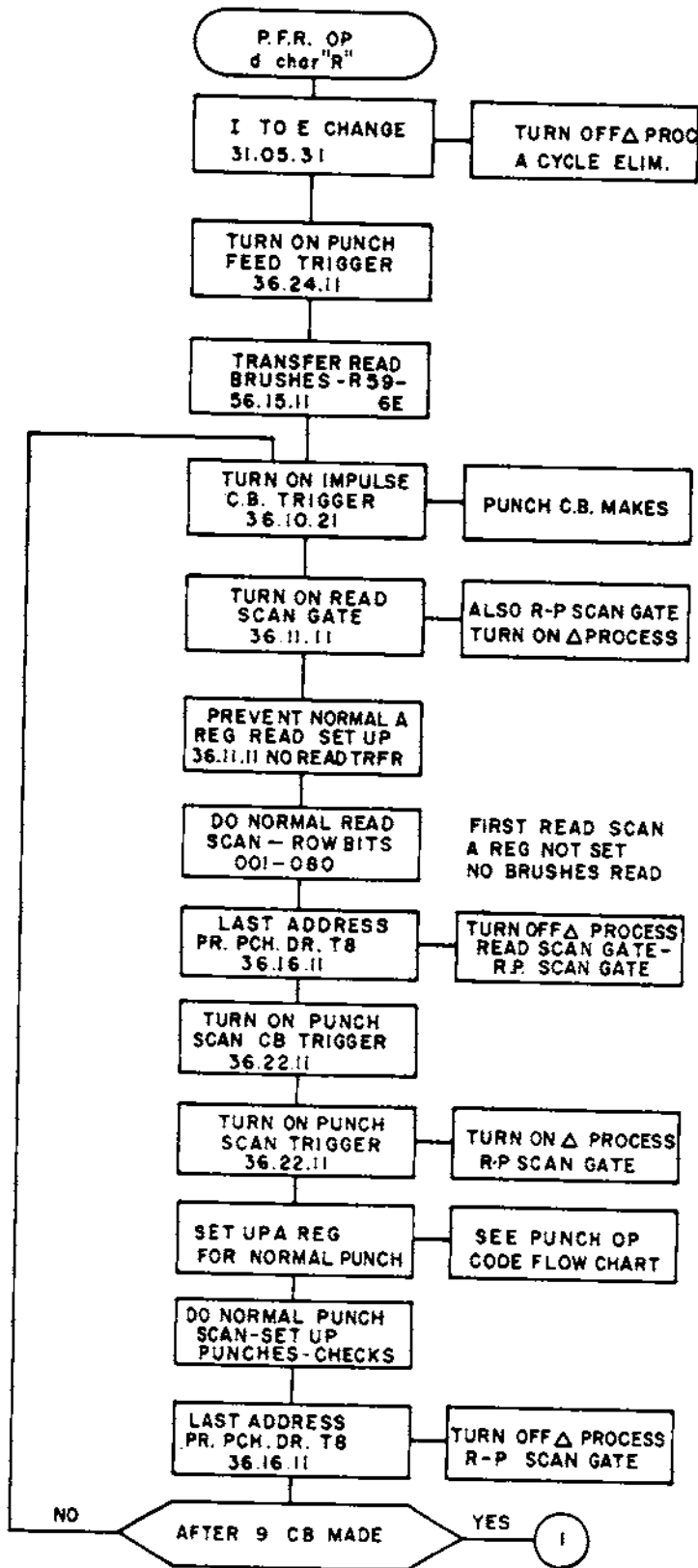

PFR OPERATION
(PART 1 OF 2)

PFR OPERATION

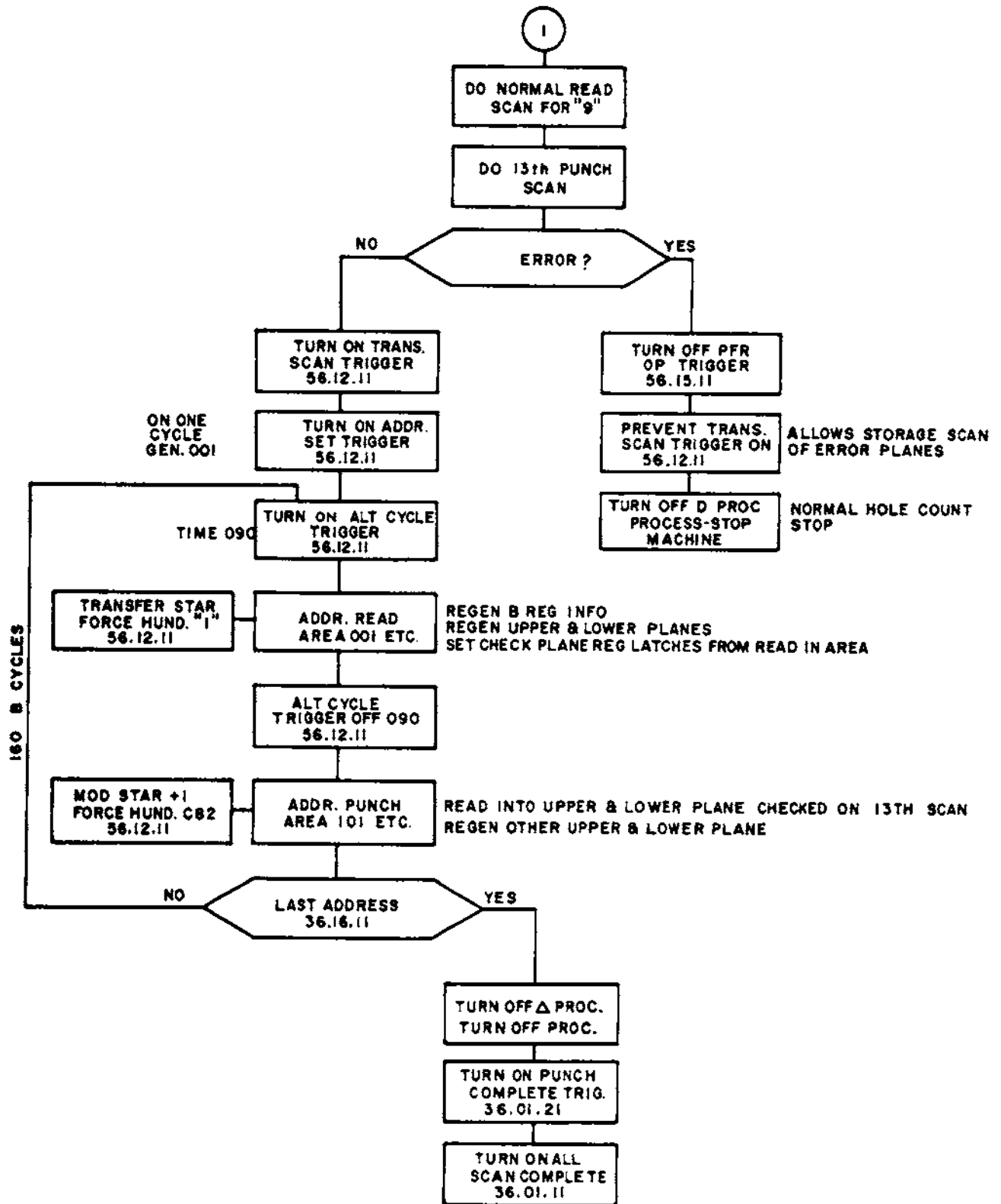

PFR OPERATION
(PART 2 OF 2)







IBM 1402 Reader Punch Service Index Printed in U.S.A. Form Number 229-4016-1

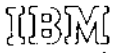

International Business Machines Corporation
Data Processing Division
112 East Post Road White Plains N.Y. 10601
USA Only

IBM World Trade Corporation
821 United Nations Plaza New York New York 10017
International